

电应普

BEST SENSOR



DATASHEET

L06-Liquefied gas liquid level sensor module

TABLE OF CONTENTS

1	Product Description	1
	1.1 General	1
	1.2 Features	1
	1.3 Advantages	1
	1.4 Applications	2
	1.5 Module Specication	2
	1.6 Mechanical Dimensions	3
	1.7 Pin out.....	3
2	Output Interface	4
	2.1 UART automatic description	4
	2.2 UART Controlled description	5
	2.3 RS485 description	7
	2.4 Modbus protocol description.....	7
	2.5 IIC description.....	11
3	Sensor Selection Instructions	15
4	Limit parameters	16
	4.1 Enviroment.....	16
	4.2 Electronics.....	16
5	Notice	17

1 .Product Description

1.1 General

L06-Liquefied gas liquid level is a sensor that uses high-frequency ultrasonic detection technology to measure the height of the liquid level of liquefied gas substances without contact. Users can connect to sensors through NB-IoT, HTTP, LoRaWAN, etc. to upload data to the platform, and can remotely monitor the use of liquefied petroleum gas.

L06-Liquefied gas liquid level is hereinafter referred to as "sensor" for description.

1.2 Features

- •3.3V~5V supply voltage
- • Sleep current is less than 15uA (UART controlled)
- • 3cm standard blind zone
- • Detection liquid level range 3-100cm
- • Output interface: UART automatic, UART controlled, IIC, RS485
- • The default baud rate is 115200, which can support 4800, 9600, 14400, 19200, 38400, 57600, 76800
- • Measurement resolution 1mm
- • Measurement accuracy $\pm(5+S*1\%)$ mm (S is the measured value)
- • Support horizontal inclination detection, range 0~180°
- • Non-contact level measurement, safe
- • Real-time tracking of the full range, no need to restart when the empty container is filled with liquid
- • Working temperature -15°C to +60°C
- • Storage temperature -25°C to +70°C
- • Dustproof and waterproof industrial design, protection grade IP67
- • Electrostatic protection design, input and output interfaces are equipped with electrostatic protection devices, in line with IEC61000-4-2 standard

1.3 Advantages

- • Small dead zone
- • Support baud rate modification
- • Intelligent judgment of successful installation, adaptive media adjustment to the best state
- • High protection level
- • Wide working temperature
- • Strong antistatic
- • Standby ultra-low power consumption
- • With temperature compensation, high measurement accuracy
- • Measurement data is stable and reliable

1.4 Applications

- Metal tank, glass fiber tank liquefied gas liquid level detection

1.5 Operating specification

Item	L062MTW	L062M4W	L062MUW	L062MCW	Unit	Remark
Output interface	UART Controlled	RS485	UARTAuto	IIC	-	
Static current	≤15	≤10000			uA	
Average operating current	≤20				mA	(1)
Operating voltage	3.3~5				V	DC
Blind zone	≤30				mm	(2)
Measurement range	30~1000				mm	(2)
Power-on working hours	≤650				ms	
Working period	>750				ms	
Resolution	1				mm	
Normal temperature accuracy	±(5+S*1%)				mm	(2)
Liquid level measurable angle	3				°	(3)
Slope value output range	0~180				°	
Measurable container thickness	1~5				mm	
Temperature compensation	Support				-	

Remarks: (1) Typical data obtained by 5V power supply and 1S duty cycle test;

(2) Normal temperature and humidity, 1 standard atmospheric pressure, and the measuring medium is propane liquefied gas (LPG); if other gases are to be tested, please specify when ordering;

(3) When the daily 15KG liquefied gas tank is full of gas, the reference angle when the level is tilted until the liquid level value cannot be measured;

(4) The measurement distance depends on the material and thickness of the tank container. If the special material or test thickness is greater than 5.0mm, it needs to be specified when ordering.

1.6 Mechanical properties

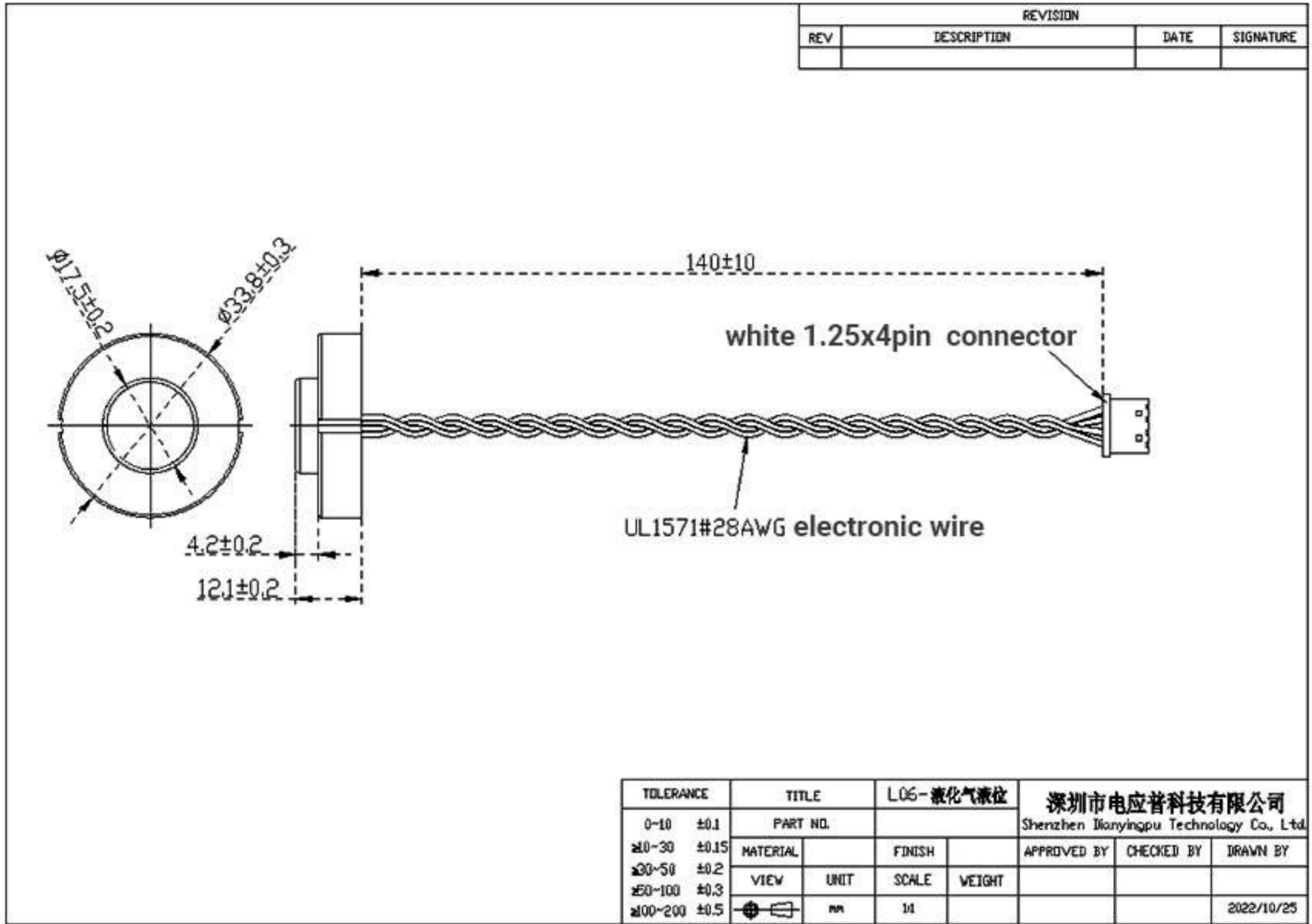

1.7 Pin out

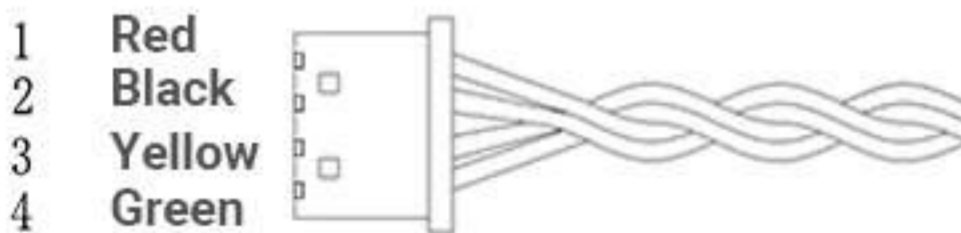

Lead number	Lead color	Lead name	Lead Description	Remark
1	red	VCC	Power input leads	
2	black	GND	Power ground lead	
3	yellow	RX/B	function lead	(1)
4	green	TX/A	function lead	(1)

Remarks: (1) There is a one-to-one correspondence between the lead wire and pin function and the output interface of the product model, and cannot coexist with other output interface.

2 .Output Interface

2.1 UART Automatic output description

2.1 (1)Pin definition

Pin No.	Lead color	Lead name	Description	Remark
1	red	VCC	Power input leads	
2	black	GND	power ground lead	
3	yellow	RX	Real time Value or Processed Value Lead	
4	green	TX	Data output lead	

Remarks: (1) There is a one-to-one correspondence between the lead wire and pin function and the output interface of the product model, and cannot coexist with other output interface.

2.1 (2) Communication instruction

When the trigger input lead "RX" is suspended or the input is high, the module outputs according to the processed value, the data is more stable, and the response time is about 800ms; when the input is low, the module outputs according to the real-time value, and the response time is about 250ms (Note: "RX" level detection is only valid within 100ms of power-on, and there will be no level detection thereafter).

UART	Data bits	Stop bit	Parity bit	Baud rate
TTL level	8	1	No	115200bps

2.1 (3) UART Output format

Data Frame	Description	Byte
Start Bit	Fixed to 0XFF	1 byte
Data_H	The upper 8 bits of the distance data, that is, the height value of the liquid level, unit: mm	1 byte
Data_L	The lower 8 bits of the distance data	1 byte
TEMP_H	The upper 8 bits of the temperature data, the temperature value is signed data, unit: 0.1°C	1 byte
TEMP_L	Lower 8 bits of temperature data	1 byte
RSSI_H	The upper 8 bits of signal strength data, unit: mV, range 0-1500, the larger the value, the better the signal	1 byte

RSSI_L	The lower 8 bits of the signal strength data	1 byte
ANGLE_H	The upper 8 bits of the tilt angle data are the horizontal tilt angle value of the sensor, unit: 0.1°, range 0~180°	1 byte
ANGLE_L	The lower 8 bits of the inclination data	1 byte
SUM	Checksum, the lower 8 bits of the cumulative value of all previous bytes	1 byte

2.1 (4) UART out example

Such as sensor output: FF 00 A0 01 38 05 DB 00 30 E8

$SUM = (0XFF + 0X00 + 0XA0 + 0X01 + 0X38 + 0X05 + 0XDB + 0X00 + 0X30) \& 0x00FF = 0XE8;$

Level value= Data_H*256+ Data_L=0X00A0, 160mm;

Temperature value= TEMP_H*256+ TEMP_L=0X0138, 31.2°C;

Signal strength= RSSI_H*256+ RSSI_L=0X05DB, 1499;

Horizontal inclination value= ANGLE_H*256+ ANGLE_L=0X0030, 4.8°.

2.2 UART Controlled Output

2.2 (1) Pin definition

Pin No.	Lead color	Lead name	Description	Remark
1	red	VCC	Power input leads	
2	black	GND	Power ground lead	
3	yellow	RX	Trigger input lead	(1)
4	green	TX	Data output lead	(1)

Remarks: (1) There is a one-to-one correspondence between the lead wire and pin function and the output interface of the product model, and cannot coexist with other output interface.

2.2 (2) Communication instruction

When the trigger input lead "RX" receives a trigger pulse with a falling edge or any serial port data, the falling edge will trigger the sensor to work once, the output lead "TX" will output a measurement data, and output 0xFFFFD when no liquid is detected, The trigger period of the sensor must be greater than 750ms.

UART	Data bits	Stop bit	Parity bit	Baud rate
TTL level	8	1	No	115200bps

2.2 (3) Timing Diagram

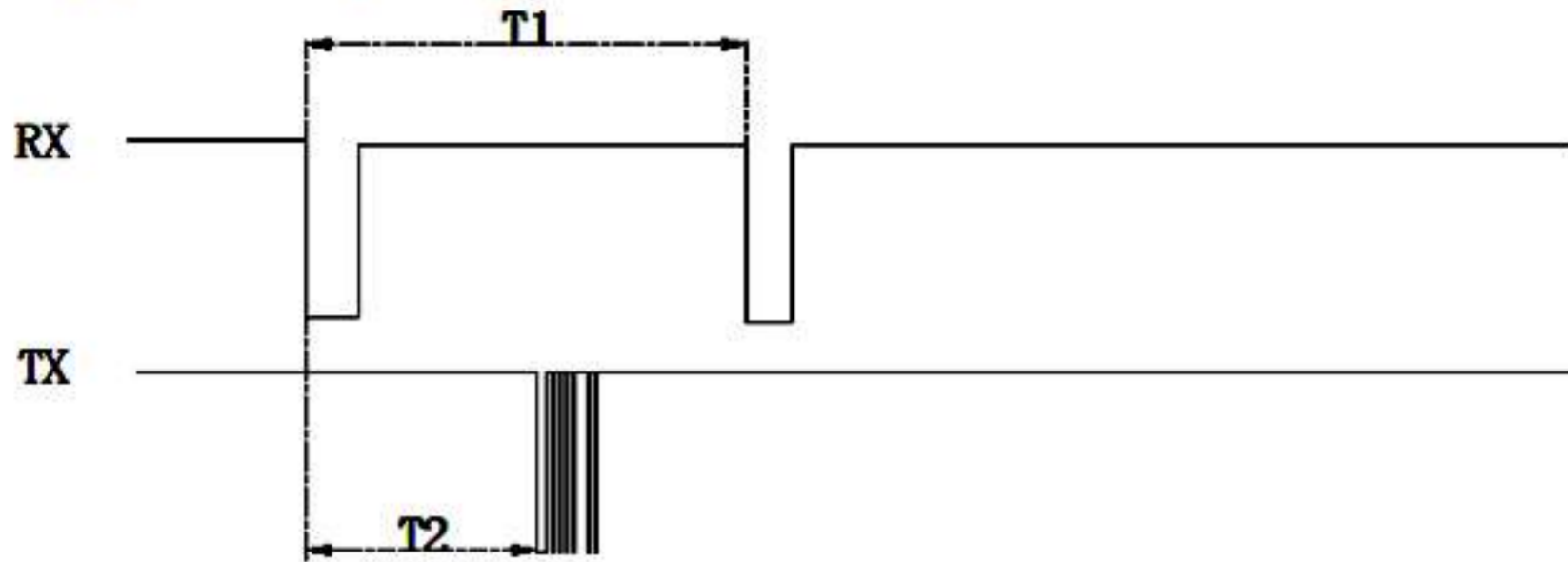

Note: $T1 > T2 + 15\text{ms}$; $T2 \approx 730\text{ms}$; measured in non-sleep mode.

2.2 (4) UART Controlled Output Format

Data Frame	Description	Byte
Start Bit	Fixed to 0XFF	1 byte
Data_H	The upper 8 bits of the distance data, that is, the height value of the liquid level, unit: mm	1 byte
Data_L	The lower 8 bits of the distance data	1 byte
TEMP_H	The upper 8 bits of the temperature data, the temperature value is signed data, unit: 0.1°C	1 byte
TEMP_L	Lower 8 bits of temperature data	1 byte
RSSI_H	The upper 8 bits of signal strength data, unit: mV, range 0-1500, the larger the value, the better the signal	1 byte
RSSI_L	The lower 8 bits of the signal strength data	1 byte
ANGLE_H	The upper 8 bits of the tilt angle data are the horizontal tilt angle value of the sensor, unit: 0.1°, range 0~180°	1 byte
ANGLE_L	The lower 8 bits of the inclination data	1 byte
SUM	Checksum, the lower 8 bits of the cumulative value of all previous bytes	1 byte

2.2(5) UART Controlled Output Example

Such as sensor output: FF 00 A0 01 38 05 DB 00 30 E8

$SUM = (0XFF + 0X00 + 0XA0 + 0X01 + 0X38 + 0X05 + 0XDB + 0X00 + 0X30) \& 0x00FF$
 $= 0XE8;$

Level value = $Data_H * 256 + Data_L = 0X00A0$, 160mm;

Temperature value = $TEMP_H * 256 + TEMP_L = 0X0138$, 31.2°C;

Signal strength = $RSSI_H * 256 + RSSI_L = 0X05DB$, 1499;

Horizontal inclination value = $ANGLE_H * 256 + ANGLE_L = 0X0030$, 4.8°.

2.3 RS485 Output Communication Instruction

2.3 (1) Pin definition

Pin No.	Lead color	Lead name	Description	Remark
1	Red	VCC	Power input leads	
2	Black	GND	Power ground lead	
3	Yellow	B	485 communication inverting terminal lead wire	(1)
4	Green	A	485 communication same-phase lead wire	(1)

Remarks: (1) There is a one-to-one correspondence between the lead wire and pin function and the output interface of the product model, and cannot coexist with other output interface.

2.3 (2) RS485 output parameter

Interface	Data bits	Stop bit	Parity bit	Baud rate
RS485 Level	8	1	No	115200bps (default)

2.3 (3) RS485 Interface Protocol

The Modbus protocol is adopted, please refer to the "Modbus Protocol Description" chapter.

2.4 Modbus protocol description

After the UART is controlled to sleep, it needs to send a falling edge pulse or arbitrary data to the RX pin to wake up, and send the modbus command again within 700ms before the sensor will receive the response.

2.4 (1) Modbus protocol parameters

Mode	Parity	Sensor Address	Read function code	Write function code
Modbus-RTU	CRC-16/MODBUS	Configurable, default 0x01	0x03	0x06

2.4 (2) Modbus protocol format

Sensor module as slave, Customer device as host:

Host

Name	Address	Function code 0x03	Register address	Register qty	CRC16 Parity
Length (Byte)	1	1	2	2	2

Slave response(read):

Name	Address	Function code 0x03	Returns the number of bytes	Data area	CRC16 Parity
Length (Byte)	1	1	1	N	2

Host sends(write):

Name	Address	Function code 0x06	Register address	Data area	CRC16 Parity
Length (Byte)	1	1	2	2	2

Slave response(write):

Name	Address	Function code 0x06	Register address	Data area	CRC16 Parity
Length (Byte)	1	1	2	2	2

2.4 (3) Modbus Register

The register data is high byte first and low byte last.

(1) Modbus Register Table 1

Status	Register	Function	Data type	Instruction
Read-only	0x0100	Processing value	unsigned int, 16 bits	Start ranging multiple times after receiving the instruction, and output the distance value after filtering, unit: mm, response time about 750ms
Read only	0x0101	Real-time value	unsigned int, 16 bits	After the sensor receives the instruction, it starts the distance measurement once, and outputs the real-time distance value, unit: mm, and the response time is about 250ms
Read only	0x0102	Tempera- -ture	Signed, 16 bit	After the sensor receives the instruction, it starts the distance measurement once, and outputs the real-time temperature value, unit: 0.1°C, and the response time is about 250ms

Read only	0x0104	Echo signal strength	unsigned int, 16 bits	After the sensor receives the instruction, it starts the distance measurement once, and outputs the real-time echo signal strength, unit: mV, range 0-1500, the larger the value, the stronger the signal, and the response time is about 250ms
-----------	--------	----------------------	-----------------------	---

(2) Modbus Register Table 2

State	Register	Function	Data type	Instruction
Read-write	0x0200	Slave address	unsigned int, 16 bits	Range: 0x01~0xFE (default 0x01), 0xFF is the broadcast address
Read-write	0x0201	Baud rate	Unsigned, 16 bit	Serial port baud rate (default 115200), unit: bps, effective immediately after setting, the baud rate corresponding to the register value is as follows: 0x0002:4800, 0x0003:9600, 0x0004:14400, 0x0005:19200, 0x0006:38400, 0x0007:57600, 0x0008:76800, 0x0009:115200

(3) Modbus Register Table 3

Status	Register	Function	Data type	Instruction
Read-write	0x0303	Installation mode	unsigned int, 16 bits	Write 0x0001 to start the installation mode, and then read the relevant data of the sensor installation mode. Write 0x0000 to end the installation mode
Read-only	0x0120	Installation status	unsigned int, 16 bits	Installation mode status value, range: 0~9, the larger the value, the better the installation status, otherwise the worse the status, such as 0-failure, 8 or 9-success. If it is not in the installation mode, it will start the installation mode and automatically measure the distance. If it does not receive this command for a period of time, it will exit.
Read-only	0x0121	Slope angle	Unsigned, 16 bit	Real-time tilt angle value, range 0.0~180.0 degrees, unit: 0.1 degrees. The horizontal inclination of the sensor can be used for auxiliary judgment during measurement and installation

Read only	0x0122	Adaptive media state	unsigned int, 16 bits	Media adaptation will be started automatically during installation mode, 0-medium adjustment not started, 2/3-media adjustment in progress, 4-media adjustment failed, 9-automatic media adaptation successful
-----------	--------	----------------------	-----------------------	--

Note: The installation mode requires a minimum liquid level of 10cm.

(4) The influence of different baud rates on the communication time of single packet data

No.	Baud rate	Communication time
1	4800	16ms
2	9600	8ms
3	14400	5.6ms
4	19200	4ms
5	38400	2.4ms
6	57600	1.6ms
7	76800	0.8ms
8	115200	0.6ms

Note: The higher the baud rate, the shorter the single packet communication time

2.4 (4) Modbus Communication example

Example 1: Reading process value data

Host: 01 03 01 00 00 01 85 F6

Slave: 01 03 02 02 F2 38 A1

Description: The sensor address is 0x01, the processing distance value is 0x02F2, converted to decimal is 754mm.

Example 2: Read real-time value data

Host: 01 03 01 01 00 01 D4 36

Slave: 01 03 02 02 EF F8 A8

Explanation: The sensor address is 0x01, the real-time distance value is 0x02EF, converted to decimal is 751mm.

Example 3: Read temperature value data

Host: 01 03 01 02 00 01 24 36

Slave: 01 03 02 01 2C B8 09

Note: The sensor address is 0x01, the real-time temperature value is 0x012C, converted to decimal is 30.0°C.

Example 4: Modify the slave address

Host: 01 06 02 00 00 05 48 71

Slave: 01 06 02 00 00 05 48 71

Note: The sensor address is changed from 0x01 to 0x05.

Example 5: Reading Baud Rate

Host: 01 03 02 01 00 01 D4 72

Slave: 01 03 02 00 03 F8 45

Description: Read the baud rate, the read baud rate is: 9600bps

Example 6: Setting the baud rate

Host: 01 06 02 01 00 03 99 B3

Slave: 01 06 02 01 00 03 99 B3

Description: Set the baud rate to 9600bps

Example 7: Start the installation mode

Host: 01 06 03 03 00 01 B8 4E

Slave: 01 06 03 03 00 01 B8 4E

Note: The sensor has started the installation mode, and will automatically detect the work and judge the installation status.

Example 8: Check the data and status of the installation mode. It is recommended to read it every 1 second. Generally, if the installation is successful within 30 seconds, the installation mode can be stopped.

Host: 01 03 01 20 00 03 05 FD

Slave: 01 03 06 00 08 00 06 00 09 E0 B3

Description: sensor installation mode data, the installation status is 8-successful, the horizontal inclination is 0.6 degrees, and the adaptive medium is 9-adjustment is successful.

Example 9: Stop installation mode

Host: 01 06 03 03 00 00 79 8E

Slave: 01 06 03 03 00 00 79 8E

Description: The sensor has stopped in install mode.

2.5 IIC output description

2.5 (1) Pin definition

Pin No.	Lead color	Lead name	Description	Remark
1	Red	VCC	Power input leads	
2	Black	GND	Power ground lead	
3	Yellow	RX	IIC clock line SCK	(1)
4	Green	TX	IIC data line SDA	(1)

Remarks: (1) There is a one-to-one correspondence between the lead wire and pin function and the output interface of the product model, and cannot coexist with other output interface.

2.5(2) IIC Sensor parameters

This sensor is a slave device and supports multiple parallel connections. The communication lines SDA and SCK need to be connected externally with pull-up resistors. The recommended size range is: 3K~10K.

Communication level: 3~5.5V

Communication rate: 10~100kbit/s

Broadcast address: 0x00

Default address: 0xE8

The 8-bit slave address described in this article is obtained by shifting the 7-bit address to the left by one bit. For example, the 7-bit address corresponding to 0xE8 is expressed as 0x74.

The user can modify the address to any one of 20 addresses: 0xD0, 0xD2, 0xD4, 0xD6, 0xD8, 0xDA, 0xDC, 0xDE, 0xE0, 0xE2, 0xE4, 0xE6, 0xE8, 0xEA, 0xEC, 0xEE, 0xF8, 0xFA, 0xFC, 0xFE.

2.5(3) Timing Diagram

(1) Read 1 byte of data

Note: The blue part above the timing is the signal generated by the slave, and the red part below the timing is the signal generated by the master.

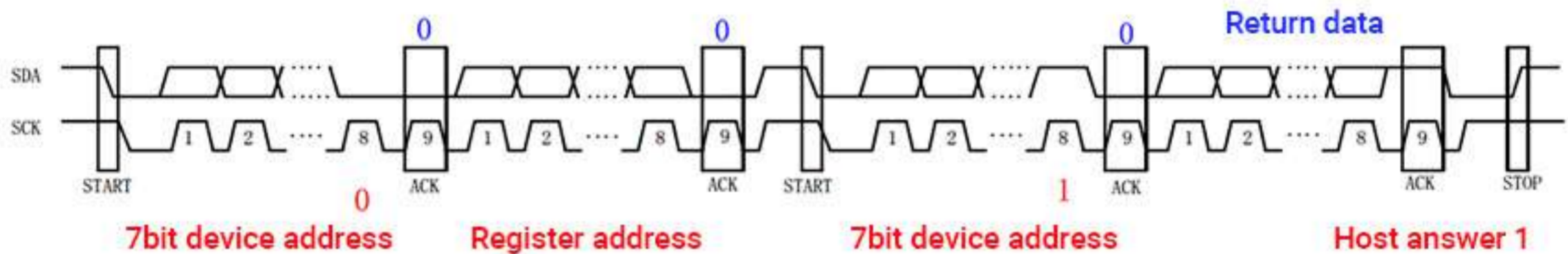

(2) Read 2 bytes of data, with the high eight bits first and the low eight bits behind

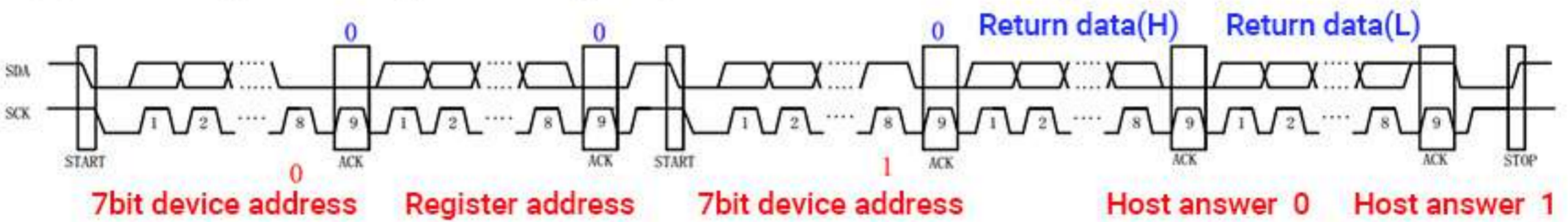

(3) Write 1 byte of data



2.5 (4) IIC register

The register data is high byte first and low byte last.

(1) IIC Register Table 1

Status	Register	Function	Data type	Instruction
Read-only	0x00 ~0x01	Program version identification	Unsigned, 16 bit	Sensor software version number identification
Read-only	0x02 ~0x03	Distance value	Unsigned, 16 bit	According to the latest trigger command, output the liquid level distance value data, unit: mm; After triggering the distance measurement, please delay the corresponding time before reading
Read-only	0x0A ~0x0B	Tempera- -ture	Signed, 16 bit	Unit: 0.1°C, can be read after triggering ranging
Read-only	0x0C ~0x0D	Echo signal strength	Unsigned, 16 bit	Echo signal strength, unit: mV, range 0~1500, the larger the value, the stronger the signal, it can be read after the ranging is triggered
Write-only	0x10	Command control	Unsigned, 8 bit/16 bit	Please refer to Table 2 for explanation
Read-write	0x11	Installation mode	Unsigned, 8 bit	Write 0x01 to start the installation mode, and then read the relevant data of the sensor installation mode. Write 0x00 to end the installation mode. Please refer to Table 3 for installation mode data
Read-write	0x20	Slave address	Unsigned, 8 bit	8-bit slave device address, default 0xE8, 0x00 is the broadcast address; Any one of the 20 addresses can be written and set: 0xD0, 0xD2, 0xD4, 0xD6, 0xD8, 0xDA, 0xDC, 0xDE, 0xE0, 0xE2, 0xE4, 0xE6, 0xE8, 0xEA, 0xEC, 0xEE, 0xF8, 0xFA, 0xFC, 0xFE

(2) IIC Register Table 2, control instruction

Status	Register	Command	Function	Instruction
Write-only	0x10	0xB0	Trigger measurement (process value)	Continuously measure multiple times after receiving the instruction, and get the measurement data after filtering. The measurement takes 750ms
Write-only	0x10	0xB4	Trigger measurement (real-time value)	After the sensor receives the instruction, it starts the distance measurement once, and obtains real-time measurement data. The measurement takes 250ms
Write-only	0x10	0xA5	Restart sensor	The slave restarts immediately after receiving the command

Note: The sensor cannot respond to the IIC command during the distance measurement, please read the IIC data after the distance measurement is completed.

(3) IICRegister Table 2, install mode data

Status	Register	Function	Data type	Instruction
Read-only	0x60 ~0x61	Installation status	Unsigned, 16 bit	Installation mode status value, range: 0~9, the larger the value, the better the installation status, otherwise the worse the status, such as 0-failure, 8 or 9-success. If it is not in the installation mode, it will start the installation mode and automatically measure the distance. If it does not receive this command for a period of time, it will exit.
Read-only	0x62 ~0x63	Slope angle	Unsigned, 16 bit	Real-time tilt angle value, range 0.0~180.0 degrees, unit: 0.1 degrees. The horizontal inclination angle of the sensor can be used for auxiliary judgment during measurement and installation; it can also be read after measurement in non-installation mode
Read-only	0x64 ~0x65	Adaptive Media State	Unsigned, 16 bit	Media adaptation will be started automatically during installation mode, 0-medium adjustment not started, 2/3-media adjustment in progress, 4-media adjustment failed, 9-automatic media adaptation successful

2.5 (5) Communication example

Example 1: The host triggers the sensor to work and reads the liquid level processing value. The operation steps are as follows:

① Send trigger ranging command:

Address (write)	0x10	0xB0
-----------------	------	------

② Wait for a delay of 800ms, during which the host can handle other processes

③ Read the distance value:

Address (write)	0x02	Address (read)	0x01	0x29
-----------------	------	----------------	------	------

The real-time distance value is 0x0129, converted to decimal is 297mm.

Example 2: The host modifies the IIC address of the sensor, the operation steps are as follows.

Original address 0xE8 (write)	0x20	New address 0xD0
-------------------------------	------	------------------

The sensor is changed from the original address 0xE8 to the new address 0xD0, save and take effect.

3 .Sensor Selection Instructions

There are four output formats for this series of sensors, and the user can choose the corresponding model according to the actual application. If there are special requirements to modify the response time, communication protocol and output mode, etc., it needs to communicate with our company when purchasing.

No.	Model No.	Output interface
1	DYP-L062MTW-V1.0	UART Controlled
2	DYP-L062MCW-V1.0	IIC
3	DYP-L062MUW-V1.0	UART Auto
4	DYP-L062M4W-V1.0	RS485

4 .Limit parameter

(1) Environment

Item	Minimum value	Typical value	Max value	Unit	Remark
Storage Temp	-25	25	70	°C	
Storage humidity	-	65%	90%	RH	(1)
Operating Temp	-10	25	60	°C	
Operating Humidity	-	65%	80%	RH	(1)

Remarks: a. When the ambient temperature is 0-39°C, the maximum humidity is 90% (no condensation)

b. When the ambient temperature is 40-50°C, the highest humidity is the highest humidity in nature at the current temperature (no condensation)

(2) Electronics

Parameter item	Parameter item			Unit	Remark
	Minimum value	Typical value	Max value		
Operating Voltage	3.3	5	5.5	V	
Peak current	-	-	50	mA	peak-to-peak
Input ripple	-	-	50	mV	peak-to-peak
Input noise	-	-	100	mV	peak-to-peak
ESD			±4K/±8K	V	(1)

Remarks: The input and output leads conform to the IEC61000-4-2 standard; contact static electricity $\pm 4\text{KV}$, air static electricity $\pm 8\text{KV}$.

5. Notice

1. The temperature range that can guarantee the detection accuracy of liquefied petroleum gas is 0-35 degrees Celsius;
2. The detection blind area and
The detection limit height is also different;
3. Containers made of the same material at normal temperature have different detection blind areas and detection limit heights due to different container thicknesses;
4. When the detected liquid level exceeds the effective detection value of the sensor, and the liquid level of the liquid to be measured shakes or tilts greatly, the height value of the detected liquid is unstable;
5. Please pay attention to the structural tolerance when designing. Unreasonable structural design may cause temporary abnormality of the sensor function;
6. Please pay attention to the evaluation of electromagnetic compatibility when designing. Unreasonable system design may cause abnormal sensor function;
7. When it comes to the boundary application of product limit parameters, you can contact the FAE of our company to confirm the relevant precautions;
8. The company reserves the right to change this document and update functions without prior notice.