

# OUTPUT

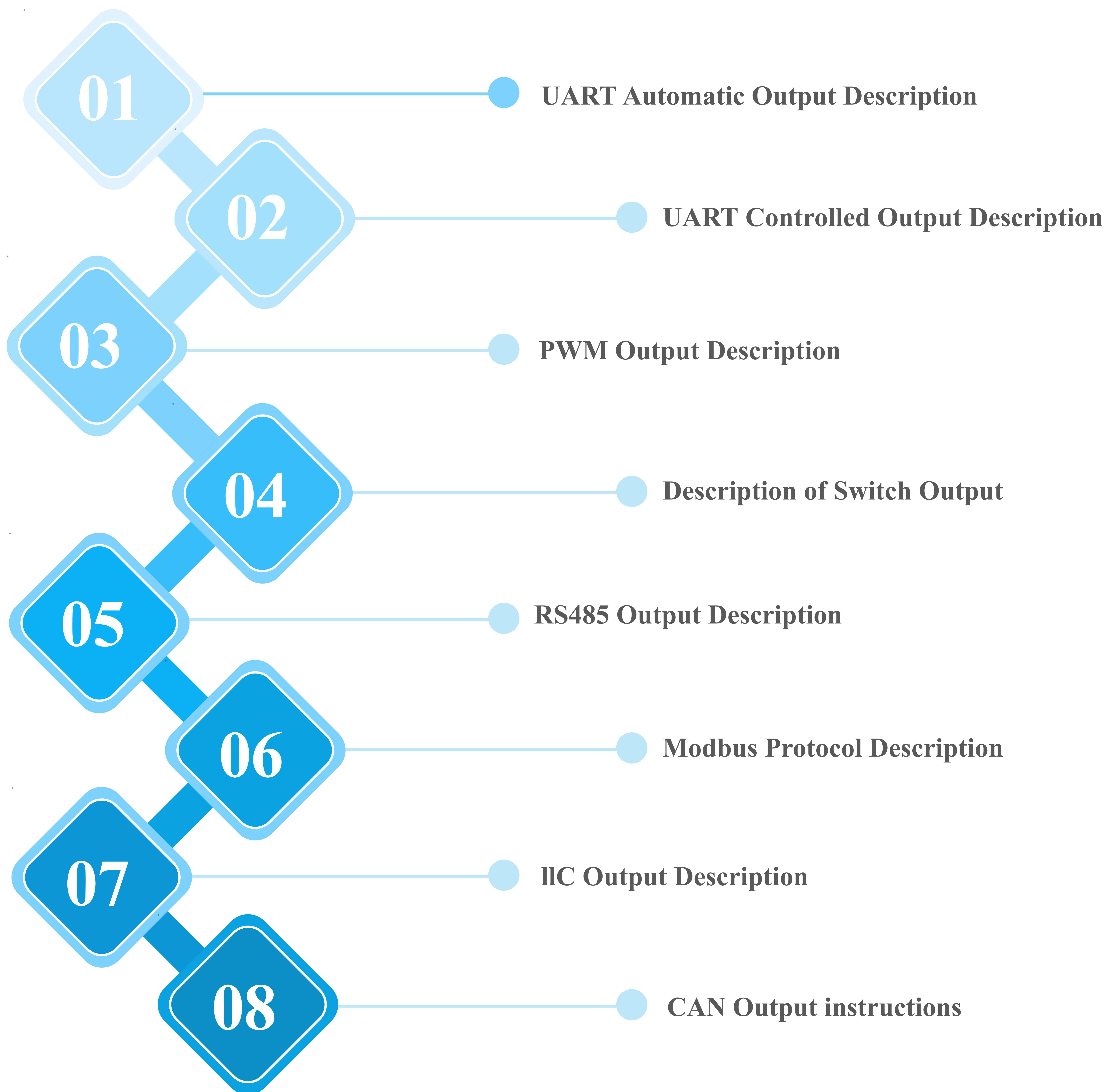

# 1. UART AUTOMATIC OUTPUT DESCRIPTION

## 1.1. Output pin definition

PIN #	PIN name	PIN description	Remarks
1	VCC	Power input	
2	GND	Ground	
3	RX	Processing value and real-time value output selection	(1)
4	TX	UART output	(1)

Remarks: (1) Lead wire, pin function and output mode of product model correspond one-to-one, and cannot coexist with other output modes.

## 1.2. UART communication description

When the trigger input lead "RX" is suspended or input high level, the module outputs according to the processed value, the data is more stable, and the response time is 100-500ms; when the input is low level, the module outputs according to the real-time value, and the response time is 100-130ms (Note: "RX" level detection is detected only valid within 500ms of power, and no level detection will be done after)

**LED light indicator: ranging 1 time red light flashing 1 time.**

UART	Data bit	Stop bit	Parity check	Baud rate
TTL level	8	1	No	115200bps

## 1.3. UART output format

Frame data	Description	Byte
Frame header	Fixed to 0XFF	1 byte
Data_H	High 8 bits of distance data	1 byte
Data_L	Low 8 bits of distance data	1 byte
SUM	Communication checksum	1 byte

Note: According to the parameter values of the modbus register 0x0209, the data output units are different, mm or us units.

## 1.4.UART output example

Frame header	Data_H	Data_L	SUM
0XFF	0X07	0XA1	0XA7

Note: The checksum only retains the lower 8 bits of the accumulated value;

$$\text{SUM} = (\text{Frame header} + \text{Data\_H} + \text{Data\_L}) \& 0x00FF$$

$$= (0XFF + 0X07 + 0XA1) \& 0x00FF$$

$$= 0XA7;$$

$$\text{Distance value} = \text{Data\_H} * 256 + \text{Data\_L} = 0X07A1;$$

Converted to decimal is equal to 1953;

When the parameter value of modbus register 0x0209 is 0x00, the unit is mm, indicates that the currently measured distance value is 1953 mm;

When the parameter value of modbus register 0x0209 is 0x01, the unit is us, indicates that the currently measured distance echo time value is 1953us, divide this value by 5.75 to get a distance value in mm units = 1953/5.75 ≈ 340mm。

## 2.UART CONTROLLED OUTPUT DESCRIPTION

### 2.1. Definition of output leads

PIN #	PIN name	PIN description	Remarks
1	VCC	Power input	
2	GND	Ground	
3	RX	Trigger input	(1)
4	TX	UART output	(1)

Remarks: (1) Lead wire, pin function and output mode of product model correspond one-to-one, and cannot coexist with other output modes.

### 2.2.UART communication description

When the trigger input lead "RX" receives a trigger pulse with a falling edge or any serial port data, the falling edge will trigger the module to work once, and the output lead "TX" will output one measurement data. The trigger cycle of the module must be greater than 150ms.

When the trigger pulse of the "RX" foot is not received for more than 5 seconds, the module goes dormant with the lowest power consumption. When the "RX" trigger pulse is received while dormant, it awakens the work immediately, but the response time increases by 12ms than when not dormant.

**LED light indicator: ranging 1 time red light flashing 1 time.**

UART	Data bit	Stop bit	Parity check	Baud rate
TTL level	8	1	No	115200bps

## 2.3. Timing diagram

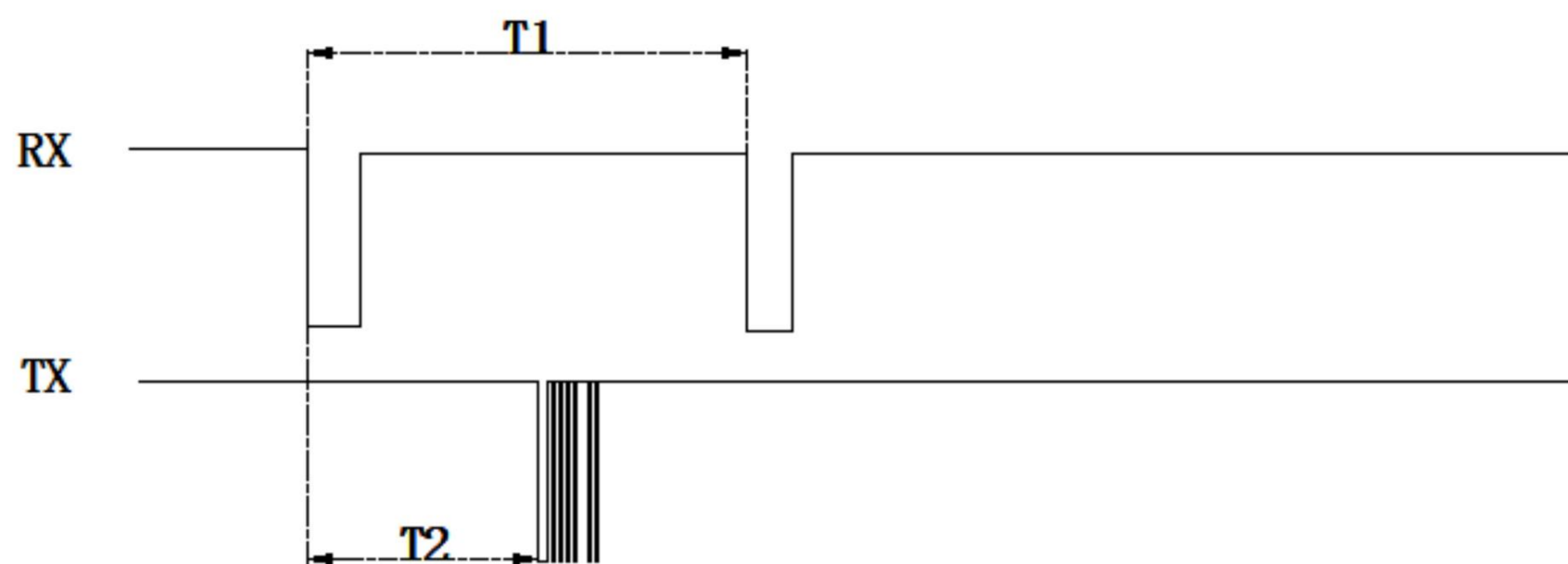

Note:  $T1 > T2 + 15\text{ms}$ ;  $T2 = 8 \sim 140\text{ms}$ ; measured in non dormant mode.

## 2.4. UART output format

Frame data	Description	Byte
Frame header	Fixed to 0XFF	1 byte
Data_H	High 8 bits of distance data	1 byte
Data_L	Low 8 bits of distance data	1 byte
SUM	Communication checksum	1 byte

## 2.5. UART output example

Frame header	Data_H	Data_L	SUM
0XFF	0X07	0XA1	0XA7

Note: The checksum only retains the lower 8 bits of the accumulated value;

$SUM = (Frame\ header + Data\_H + Data\_L) \& 0x00FF$

$= (0XFF + 0X07 + 0XA1) \& 0x00FF$

$= 0XA7;$

Distance value =  $Data\_H * 256 + Data\_L = 0X07A1;$

Converted to decimal is equal to 1953;

When the parameter value of modbus register 0x0209 is 0x00, the unit is mm, indicates that the currently measured distance value is 1953 mm;

When the parameter value of modbus register 0x0209 is 0x01, the unit is us, indicates that the currently measured distance echo time value is 1953us, divide this value by 5.75 to get a distance value in mm units  $= 1953 / 5.75 \approx 340mm$ .

## 3.PWM OUTPUT DESCRIPTION

### 3.1. Definition of output leads

PIN #	PIN name	PIN description	Remarks
1	VCC	Power input	
2	GND	Ground	
3	RX	Trigger input	(1)
4	TX	PWM output	(1)

Remarks: (1) Lead wire, pin function and output mode of product model correspond one-to-one, and cannot coexist with other output modes.

### 3.2. Description of PWM trigger

When the trigger input lead "RX" receives a trigger pulse with a falling edge or any serial port data, the falling edge will trigger the module to work once, and the output lead "TX" will output one measurement data. The trigger cycle of the module must be greater than 70ms.

When the trigger pulse of the "RX" foot is not received for more than 5 seconds, the module goes dormant with the lowest power consumption. When the "RX" trigger pulse is received while dormant, it awakens the work immediately, but the response time increases by 12ms than when not dormant.

LED light indicator: ranging 1 time red light flashing 1 time.

### 3.3. Timing diagram

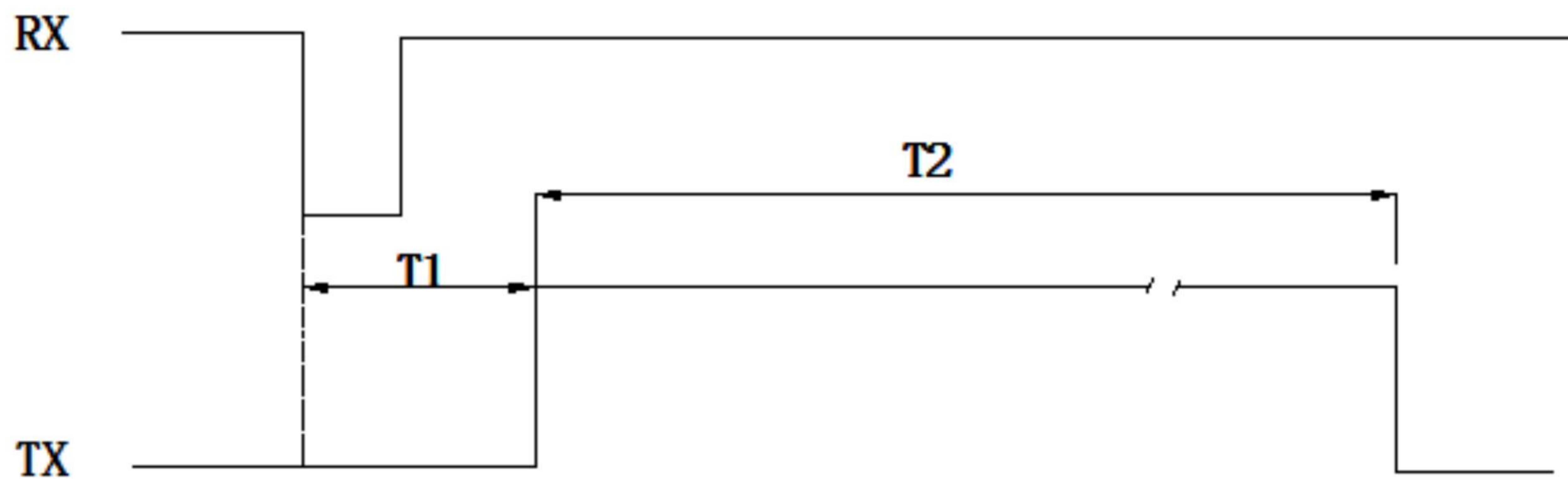

Note: T1=5~8ms (measured in non dormant mode) ; T2=0.18~30ms(PWM high-level pulse width time); a pulse width of 10us was detected for the output of the same frequency interference.

### 3.4. Calculation method

Formula:  $S = T * V / 2$  (S is the distance value, T is the PWM high-level pulse width time, and V is the sound propagation speed in the air).

Under normal temperature, the sound velocity V is 348M/S, and the formula can be simplified to get  $S = T / 57.5$  (the distance S is in centimeters and the time T is in microseconds).

Example: When the PWM high-level pulse width time T3 of the output lead "TX" is 10000us,

$S = T / 57.5 = 10000 / 57.5 \approx 173.9$ (cm), which means that the currently measured distance value is 173.9 cm.

## 4. DESCRIPTION OF SWITCH OUTPUT

### 4.1. Definition of output leads

Pin#	Pin name	Pin description	Remarks
1	VCC	Power input	
2	GND	Ground	
3	RX	Processing value and real-time value output selection、Communication receiving	(1)
4	TX	Switch output	(1)

Remarks: (1) Lead wire, pin function and output mode of product model correspond one-to-one, and cannot coexist with other output modes.

## 4.2. Working description

The module will set a threshold value at the factory, the default is 1.5 meters. The module performs distance measurement every 130ms(scale grade 5).

To improve stability, when the factory default module RX lead is suspended or the high level is input , the module outputs according to the processing value, If the target distance is less than the threshold value for 15 consecutive times, the TX lead output is high level, that is, the response time is about 2S; If the target distance is less than the threshold value for 25 consecutive times, the TX lead output is low level, that is, the retention time is about 3.2S. When the RX lead is input at low level, the module outputs it at real-time values, with a response time of about 0.4s and a retention time of about 0.6s.

Both the threshold and the output polarity parameters can be set, if the output polarity is positive output(0x01),when the detected distance value of the target is less than the set threshold value, the output is at a high level,when the detected distance value is greater than the set threshold, the output is at a low level. With a negative output(0x00), the level logic is reserved.(Note:RX lead level detection is only effective within 800ms of power-up,and no level detection will be done after that. The module TX lead only outputs high and low level signals and has no driving capability. If there are special requirements that need to change threshold or other settings, special instructions are required when purchasing.)

LED light indicator: ranging 1 time red light flashing 1 time.

## 4.3. Set the threshold value and output polarity

### (1) Communication line connection

Connect the RX and TX of the module leads to the TXD and RXD of the host side,serial port communication is available.

### (2) Communication serial port setting

UART	Data bit	Stop bit	Parity check	Baud rate
TTL level	8	1	No	115200bps

Only set valid during the module power on (within 500ms after the power on), 100 ms interval, the instructions are repeatedly sent, until the module responds.

### (3) Modify the threshold data format

The user machine is the host machine equipment, and this module is the slave equipment.

**Host sent:**

Name	Frame header	command code	High threshold values	Low threshold values	Checksum
Byte	Fixed to 0XFB	Fixed to 0X05	1 byte	1 byte	1 byte

**Slave respond:**

Name	Frame header	command code	High threshold values	Low threshold values	Status bit	Checksum
Byte	Fixed to 0XFB	Fixed to 0X85	1 byte	1 byte	success: 0X00 fail: 0X01	1byte

Note: checksum = (frame header + command code + High threshold values + Low threshold values + Status bit) & 0x00FF

**Example 1:**

Host : FB 05 03 E8 EB(checksum=(0XFB+0X05+0X03+0XE8)&0X00FF=0XEB)

Slave : FB 85 03 E8 00 6B

Indicates that the setting is successful, set the switch distance to 1000mm.

Threshold setting range: 30~5000mm。

**(4) Modify the switch volume polarity data format**

The user machine is the host machine equipment, and this module is the slave equipment.

**Host sent:**

Name	Frame header	Command code	Hold	Output polarity	checksum
Byte	Fixed to 0XFB	Fixed to 0X06	0X00	0x00: negative output, Output low level below threshold; 0x01: positive output, Output high level below threshold	1 byte

**Slave response:**

Name	Frame header	Command code	Hold	Output polarity	Status bit	checksum
Byte	Fixed to 0XFB	Fixed to 0X86	0X00	High level: 0X01 Low level : 0X00	success: 0X00 fail: 0X01	1 byte

Note : checksum = (frame header + command code + output polarity + status bit)&0x00FF

**Example 1:**

Host : FB 06 00 01 02(checksum=(0XFB+0X06+0X00+0X01)&0X00FF=0X02)

Slave : FB 86 00 01 00 82

Indicate that the setting is successful, when the module is set to detect an object, the "TX" lead output high level, and the "RX" lead output low level.

Example 2:

Host : FB 06 00 00 01(checksum=(0XFB+0X06+0X00+0X00)&0X00FF=0X01)

Slave : FB 86 00 00 00 81

Indicate that the setting is successful, when the module is set to detect an object, the "TX" lead output low level, and the "RX" lead output high level.

## 5.RS485 OUTPUT DESCRIPTION

LED light indicator: ranging 1 time red light flashing 1 time.

### 5.1.RS485 output leads definition

Pin #	Pin name	Pin description	Remarks
1	VCC	Power input	
2	GND	Ground	
3	B	485 Communication anti-phase terminal	(1)
4	A	485 Communication in the same terminal	(1)

Remarks: (1) Lead wire, pin function and output mode of product model correspond one-to-one, and cannot coexist with other output modes.

### 5.2.RS485 interface parameters

Interface	Data bit	Stop bit	Parity check	Baud rate
RS485 level	8	1	No	115200bps(default)

### 5.3.RS485 interface protocol

Adopt the Modbus protocol, please refer to the "Modbus protocol specification" chapter.

## 6.MODBUS PROTOCOL DESCRIPTION

UART controlled、PWM controlled、switch output only supports the serial port Modbus protocol within 500ms. UART automatic、RS485 output mode does not have this limitation, sustainable communication after power-up.

## 6.1.The Modbus protocol parameters

Model	Check	Sensor address	Read the function code	Write the function code
Modbus-RTU	CRC-16/MODBUS	Setable, default 0x01	0x03	0x06

## 6.2.The Modbus protocol format

The user machine is the host machine equipment, and this module is the slave equipment.

**Host sent(read):**

Name	Device address	Function code 0x03	Register address	Register number	CRC16 check
Length(Byte)	1	1	2	2	2

**Slave response(read):**

Name	Device address	Function code 0x03	Return bytes number	Data field	CRC16 check
Length(Byte)	1	1	1	N	2

**Host sent(write):**

Name	Device address	Function code 0x06	Register address	Data field	CRC16 check
Length (Byte)	1	1	2	2	2

**Slave response(read):**

Name	Device address	Function code 0x06	Register address	Data field	CRC16 check
Length (Byte)	1	1	2	2	2

## 6.3.The Modbus register

Register data for high bytes in front and low bytes in back.

(1) Modbus register table 1

Authority	address	function	Data type	Instruction
Read-only	0x0100	Processing value	Unsigned int, 16bit	Start raging after receiving instruction, output distance value after the algorithm processing unit: mm, response time is about 190~750ms(difference according to range)
Read-only	0x0101	Real-time value	Unsigned int, 16bit	After receiving the instruction, the module starts raging once, and outputs the real-time distance value, unit: mm, response time is about 15~140ms(difference according to range)
Read-only	0x0102	Temperature	Signed int, 16bit	Unit: 0.1°C, Resolution: 0.5°C, response time is about 5~140ms(difference according to range)
Read-only	0x010A	Echo time	Unsigned int, 16bit	After receiving the instruction, the module starts raging once, and outputs the real-time echo time, unit: us, this value is divided by 5.75 to obtain a distance value in mm unit, response time is about 5~140ms(difference according to range)

Note :The response time is measured in 0.5~5 meters, shorter the range and faster the response time.

**(2) Modbusregister table 2**

Authority	Address	Function	Data type	Instruction
Read-write	0x0200	Slave address	Unsigned int, 16bit	range: 0x01~0xFE(default 0x01), 0xFF is the broadcast address
Read-write	0x0201	Baud rate	Unsigned int, 16bit	Serial port baud rate(default 115200), unit: bps, effective immediately after setting, baud rate corresponding to register value is as follows: 0x0002:4800, 0x0003:9600, 0x0004:14400, 0x0005:19200, 0x0006:38400, 0x0007:57600, 0x0008:76800, 0x0009:115200
Read-write	0x0205	Switch output polarity	Unsigned int, 16bit	Set the switch output polarity, only the switch mode is valid; 0x00: negative output, less than the threshold value and output low 0x01: positive output, less than the threshold value and output high(default)

Read-write	0x0206	Set the switch threshold value	Unsigned int, 16bit	Set the switch threshold value,unit: mm, range: 30~5000mm, only the switch mode is valid
Read-write	0x0208	Detection angle level	Unsigned int, 16bit	<p>The angle level can be set to level 1~4,(default level 4); the larger the level, the greater the detection angle, the more sensitive the induction, and the smaller the opposite.</p> <p>1-Single angle about 50° , double-angle horizontal angle about 50° , Vertical angle about 65° ;</p> <p>2-Single angle about 55° , double-angle horizontal angle about 55° , Vertical angle about 70° ;</p> <p>3-Single angle about 65° , double-angle horizontal angle about 60° , Vertical angle about 75° ;</p> <p>4-Single angle about 70° , double-angle horizontal angle about 65° , Vertical angle about 90° ;</p>
Read-write	0x0209	Output distance value data units	Unsigned int, 16bit	Controlled / automatic output protocol distance value unit,0x00-mm, 0x01-us(This value is divided by 5.75 to obtain a distance value in mm units), Effective only for the UART automatic and UART controlled modes
Read-write	0x021A	Power noise reduction level	Unsigned int, 16bit	<p>The power noise reduction level is 1 to 5 (the default is 1) to be suitable for different power supply scenarios; The higher the level, the greater the noise suppression, and the overall angle will also be affected, and the higher the level, the more affected.Description of the different levels:</p> <p>1-Suitable for battery-powered occasions;</p> <p>2-Suitable for occasions with a certain high-frequency noise like USB power supply;</p> <p>3-Suitable for longer distance USB power supply occasions;</p> <p>4-Suitable for the occasion of switching power supply;</p> <p>5-Suitable for switching power supply, environmental interference complex occasions, generally not recommended to use;</p>

Read-write	0x021F	Scale grade	Unsigned int, 16bit	Distance measurement range level 1~5(the default is 5), range scope: 1- about 50cm, Real-time value response time 15~80ms, Processing value response time 190~500ms; 2- about 150cm, Real-time value response time 20~90ms, Processing value response time 230~550ms; 3- about 250cm, Real-time value response time 25~100ms, Processing value response time 250~600ms; 4- about 350cm, Real-time value response time 35~110ms, Processing value response time 280~650ms; 5- about 500cm, Real-time value response time 40~140ms, Processing value response time 320~750ms。
------------	--------	-------------	------------------------	--

## 6.4.Modbus communication example

Example 1: read the processing data

Host : 01 03 01 00 00 01 85 F6

Slave: 01 03 02 02 F2 38 A1

instruction: The sensor address is 0x01, The processing distance value is 0x02F2, Convert to a decimal into 754mm。

Example2: read the real-time data

Host : 01 03 01 01 00 01 D4 36

Slave : 01 03 02 02 EF F8 A8

instruction: The sensor address is 0x01, The real-time distance value is 0x02EF, Convert to a decimal into 751mm。

Example3: read the temperature data

Host : 01 03 01 02 00 01 24 36

Slave : 01 03 02 01 2C B8 09

instruction: The sensor address is 0x01, The real-time temperature value is 0x012C, Convert to a decimal into 30.0°C。

Example 4: modify the slave address

Host : 01 06 02 00 00 05 48 71

Slave : 01 06 02 00 00 05 48 71

instruction: The sensor address was modified from 0x01 to 0x05.

Example 5: read the baud rate

Host : 01 03 02 01 00 01 D4 72

Slave: 01 03 02 00 03 F8 45

instruction: Read the port rate, the read baud rate is: 9600bps

Example 6: set the baud rate

Host : 01 06 02 01 00 03 99 B3

Slave : 01 06 02 01 00 03 99 B3

instruction: set the baud rate to 9600bps

## 7.IIC OUTPUT DESCRIPTION

### 7.1.Definition of output leads

Pin #	Pin name	Pin description	Remarks
1	VCC	Power input	
2	GND	Ground	
3	RX	IIC clock line SCK	
4	TX	IIC data wire SDA	

### 7.2.IIC module parameters

This module is a slave equipment and supports multiple parallel connections. Communication line SDA and SCK need the user externally parallels the pull-up resistor, the recommended size range is: 3K~10K。

Communication level: equal to VCC

Communication rate: 10~100kbit/s

Broadcast address : 0x00

Default address : 0xE8

The 8-bit slave address described in this paper is obtained from the 7-bit address, for example, the corresponding 7-bit address of 0xE8 is expressed as 0x74.

Users can modify the address to any one of the 20 addresses: 0xD0, 0xD2, 0xD4, 0xD6, 0xD8, 0xDA, 0xDC, 0xDE, 0xE0, 0xE2, 0xE4, 0xE6, 0xE8, 0xEA, 0xEC, 0xEE, 0xF8, 0xFA, 0xFC, 0xFE。

LED indication: Range measurement 1 time red light flashing 1 time, 0x04~0x07 register parameters can be saved by power down after setting, the blue LED will illuminate for a short period of time after a successful modification.

## 7.3.IIC timing diagram

### (1) read 1 byte of data

Note :The blue part above the sequence is the signal generated by the slave, and the red part below the sequence is the signal generated by the host.

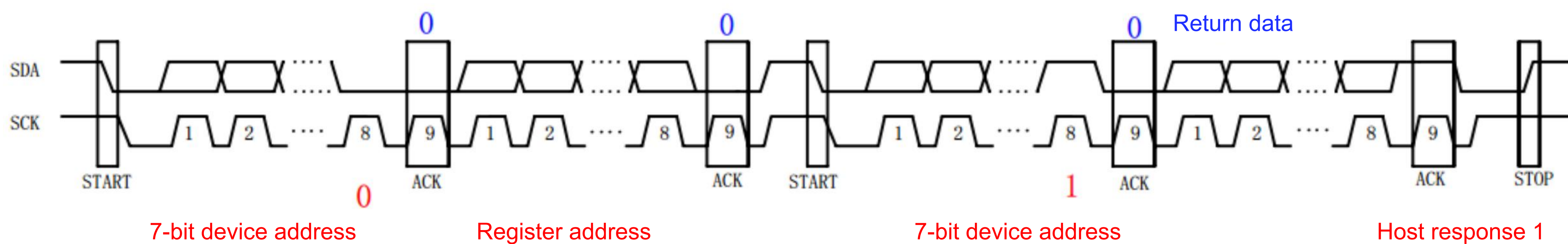

### (2) read two bytes of data, high eight in the anterior and lower eight in the posterior

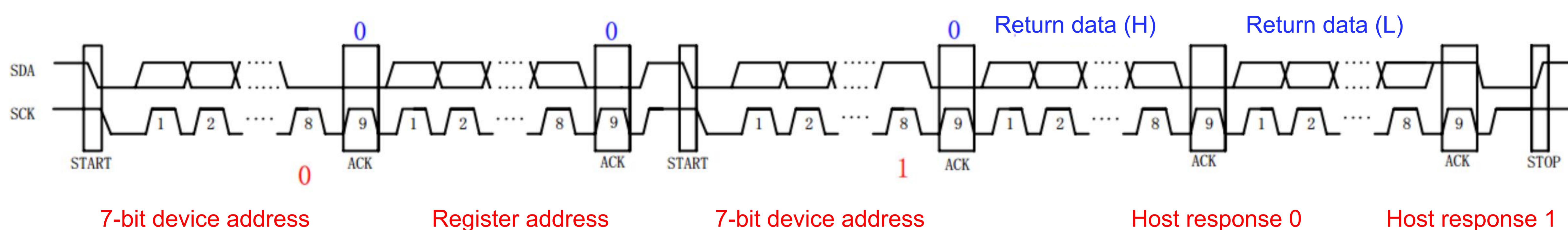

### (3) write 1 byte of data

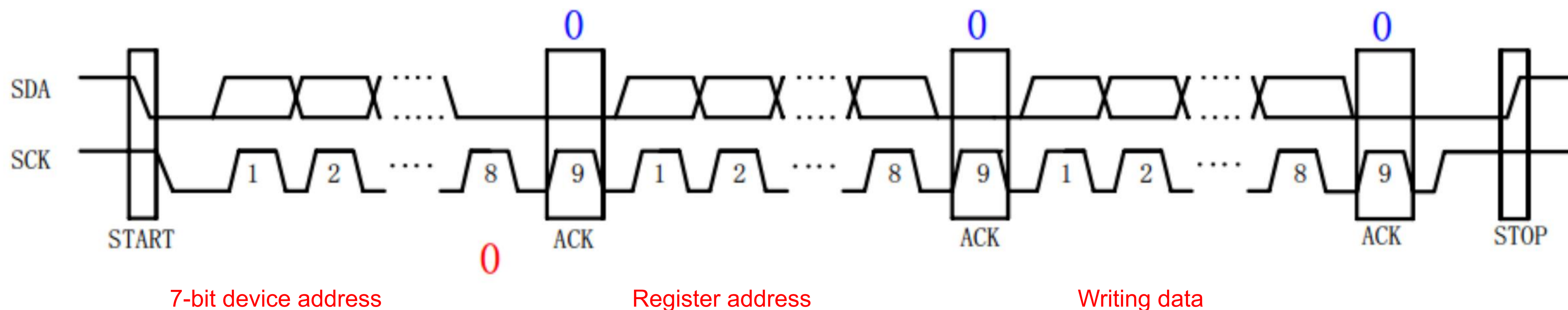

Note :When the communication rate exceeds 40 k bit/s, a 20us delay is increased after the descending edge of the ninth SCK clock (after the ACK position)

## 7.4.IIC timing diagram

Register data for high bytes in front and low bytes in back.

### (1) IIC register table 1

Authority	Register	Function	Data type	instruction
Read-only	0x00~0x01	Program version identification	Unsigned int, 16bit	Module software version number identification

Read-only	0x02~0x03	Distance value	Unsigned int, 16bit	Output the real-time distance value, output the real-time distance value,decide the output unit according to trigger instruction, the data has mm and us unit; It is recommended that the distance value be read above the trigger ranging after delaying the corresponding time
read-write	0x05	Slave address	Unsigned int, 8bit	8-bit slave device address, default 0xE8,0x00 is broadcast address; any one of the 20 set addresses can be written into: 0xD0, 0xD2, 0xD4, 0xD6, 0xD8, 0xDA, 0xDC, 0xDE, 0xE0, 0xE2, 0xE4, 0xE6, 0xE8, 0xEA, 0xEC, 0xEE, 0xF8, 0xFA, 0xFC, 0xFE
read-write	0x06	Power noise reduction level	Unsigned int, 8bit	Power noise reduction level (default is 1) is suitable for different power supply scenarios; the higher the level, the greater the noise suppression, and the measured object with a small signal may not be detected. Different levels indicate: 1-Suitable for battery-powered occasions; 2-Suitable for USB power supply and other occasions with a certain high-frequency noise; 3-Suitable for longer distance USB power supply occasions; 4-Suitable for the occasion of switching power supply; 5-Suitable for switching power supply, environmental interference complex occasions, generally not recommended to use
read-write	0x07	Angle level	Unsigned int, 8bit	The angle level can be set to level 1~4,(default level 4); the larger the level, the greater the detection angle, the more sensitive the induction, and the smaller the opposite. 1-Single angle about 50° , double-angle horizontal angle about 50° , Vertical angle about 65° ; 2-Single angle about 55° , double-angle horizontal angle about 55° , Vertical angle about 70° ; 3-Single angle about 65° , double-angle horizontal angle about 60° , Vertical angle about 75° ; 4-Single angle about 70° , double-angle horizontal angle about 65° , Vertical angle about 90° ;

read-only	0x09	Hold		
read-only	0x0A~ 0x0B	temperature	Signed int, 16bit	Unit : 0.1°C, resolution: 0.5°C, Read after trigger ranging
Write-only	0x10	instruction control	Unsigned int, 8bit/16bit	Please see table 2 for instructions

**(2) IIC register table 2, control instruction**

Authority	Register	Instruct	Function	Instruction
Write-only	0x10	0xBD	Trigger the range once	Specified ranging range is range level 1 (about 50cm), returning mm unit distance value; Measurement takes 15~80ms; please read the distance value after ranging completion, early reading 0x02 register will answer 0xFFFF
Write-only	0x10	0xBC	Trigger the range once	Specified ranging range is range level 2(about 150cm), returning mm unit distance value; measurement takes about 20~90 ms
Write-only	0x10	0xB8	Trigger the range once	Specified ranging range is range level 3(about 150cm), returning mm unit distance value; measurement takes about 25~100 ms
Write-only	0x10	0xB4	Trigger the range once	Specified ranging range is range level 4(about 350cm), returning mm unit distance value; measurement takes about 35~110ms
Write-only	0x10	0xB0	Trigger the range once	Specified ranging range is range level 5(about 500cm), returning mm unit distance value; measurement takes about 40~140ms
Write-only	0x10	0x05	Trigger the range once	Specified ranging range is range level 1 (about 50cm), returning us unit echo time value, divided this value by 5.75 to obtain the mm unit distance value; Measurement takes 15~80ms; please read the distance value after ranging completion, early reading 0x02 register will answer 0xFFFF

Write-only	0x10	0x0A	Trigger the range once	Specified as scale grade 2(about 150cm), returning us unit echo time value; measurement takes about 115 ms
Write-only	0x10	0x0F	Trigger the range once	Specified as scale grade 3(about 250cm), returning us unit echo time value; measurement takes about 20~90ms
Write-only	0x10	0xB2	Trigger the range once	Specified as scale grade 4(about 350cm), returning us unit echo time value; measurement takes about 35~110ms
Write-only	0x10	0xB9	Trigger the range once	Specified as scale grade 5(about 500cm), returning us unit echo time value; measurement takes about 40~140ms
Write-only	0x10	0x5A+0xA5	Restart the sensor	The slave restarts immediately after receiving the command

## 7.5.Communication example

**Example 1:** Read the module software version number, the operation step is:

Address (write)	0x00	Address (read)	0x00	0x01
-----------------	------	----------------	------	------

The module is identified by the software version number as 0x0001.

**Example 2:** The trigger module is ranging at a 5 meter range and reads the real-time distance value, the operation step is:

① Send the trigger ranging instructions:

Address (write)	0x10	0xB0
-----------------	------	------

Delay wait fo50ms

③ Read the distance value:

Address (write)	0x02	Address (read)	0x04	0xE9
-----------------	------	----------------	------	------

The real-time distance value is 0x04E9, convert to a decimal into 1257mm。

**Example 3:** Host modifies the module IIC address, the operation step is:

Original address 0xE8(write)	0x05	New address 0xD0
---------------------------------	------	---------------------

The module is changed from the original address 0xE8 to the new address 0xD0, which is saved and takes effect, the blue LED will illuminate for a short period of time after the successful setting.

**Example 4:** Modify the module detection angle, the operation step is:

Address (write)	0x07	0x04
-----------------	------	------

The module was modified from the detection angle level to level 4.

## 8.CAN OUTPUT INSTRUCTIONS

### 8.1. Output pin definition

PIN #	PIN name	PIN description	Remarks
1	VCC	Power input	
2	GND	Ground	
3	CANL	CAN communication lead L	(1)
4	CANH	CAN communication lead H	(1)

### 8.2. CAN Communication parameters

Frame format	Frame type	Baud rate	CAN ID	Remarks
Standard frame	data frame	Default 250Kbps (can be modified by instruction)	0x0520+slave address,default is 0x0521	

This module is a controlled instruction response mode, which supports multiple parallel CAN buses .

working current :  $\leq 17\text{mA}$

Standby current:  $\leq 14\text{mA}$

### 8.3. CAN protocol data zone format

The CAN standard communication data area is up to 8 bytes, which varies according to the number of different data area bytes of the instruction. The data format is modified according to the modbus protocol. The user machine is the host machine, and this module is the slave machine controlled device.

Byte order	Host sent (read)	Slave response (read)	Host sent (write)	Slave response (write)
1	Slave address	Slave address	Slave address	Slave address
2	FC 0x03	FC 0x83	FC 0x06	FC 0x86
3	Register address H	Return bytes	Register address H	Register address H
4	Register address L	Register data H	Register address L	Register address L
5	Register number H	Register data L	Register data H	Register data H
6	Register number L	/	Register data L	Register data L

Note: The number of registers for reading is fixed to 0x0001.

## 8.4. CAN Communication register

Register data for high bytes in front and low bytes in back.

### (1) Register table 1

Authority	Address	Function	Data type	Instruction
Read-only	0x0000	software release	Unsigned int, 16bit	Module software version number, hex values
Read-only	0x0100	Handled Value	Unsigned int, 16bit	Start raging after receiving instruction, output distance value after the algorithm processing unit: mm, response time is about 190~750ms(difference according to range)
Read-only	0x0101	Real Value	Unsigned int, 16bit	After receiving the instruction, the module starts raging once, and outputs the real-time distance value, unit: mm, response time is about 15~140ms(difference according to range)
Read-only	0x0102	Temperature	Signed int 16 bit	Unit: 0.1°C, Resolution: 0.5°C, response time is about 5~140ms(difference according to range)

Read-only	0x010A	Echo time	Unsigned int, 16bit	After receiving the instruction, the module starts ranging once, and outputs the real-time echo time, unit: us, this value is divided by 5.75 to obtain a distance value in mm unit, response time is about 5~140ms(difference according to range)
-----------	--------	-----------	------------------------	--

Note :The response time is measured in 0.5~5 meters, shorter the range and faster the response time.

**(2) register table 2**

Authority	Address	Function	Data type	Instruction
Read-write	0x0200	Slave address	Unsigned int, 16bit	range: 0x01~0xFE(default 0x01), 0xFF is the broadcast address“0x0520+slave address”gets the CAN ID, and if the slave address is 0x01, the CAN ID is 0x0521
Read-write	0x0208	Detection Angle level	Unsigned int, 16bit	The angle level can be set to level 1~4,(default level 4); the larger the level, the greater the detection angle, the more sensitive the induction, and the smaller the opposite. 1-Single angle about 50° , double-angle horizontal angle about 50° , Vertical angle about 65° ; 2-Single angle about 55° , double-angle horizontal angle about 55° , Vertical angle about 70° ; 3-Single angle about 65° , double-angle horizontal angle about 60° , Vertical angle about 75° ; 4-Single angle about 70° , double-angle horizontal angle about 65° , Vertical angle about 90° ;
Read-write	0x020A	CAN baud rate	Unsigned int, 16bit	CAN output mode only; default 0x06,250kbps; 0x04-100Kbps, 0x05-125Kbps, 0x06-250Kbps, 0x07-500Kbps, 0x08-1Mbps

Read-write	0x021F	Scale grade	Unsigned int, 16bit	Distance measurement range level 1~5(the default is 5), range scope: 1- about 50cm, Real-time value response time 15~80ms, Processing value response time 190~500ms; 2- about 150cm, Real-time value response time 20~90ms, Processing value response time 230~550ms; 3- about 250cm, Real-time value response time 25~100ms, Processing value response time 250~600ms; 4- about 350cm, Real-time value response time 35~110ms, Processing value response time 280~650ms; 5-about 500cm, Real-time value response time 40~140ms, Processing value response time 320~750ms.
------------	--------	-------------	------------------------	---

After the success of the parameter settings, blue LED lights up for a short period of time.

## 8.5. CAN communication example

Example 1: Read the processing data

Host sent, CAN ID: 0x0521, data zone: 01 03 01 00 00 01

Slave response, CAN ID: 0x0521, data zone: 01 83 02 02 F2

Note: The module slave address is 0x01, processing distance value is 0x02F2, Convert to a decimal into 754mm。

Example2: Read the real-time data

Host sent, CAN ID: 0x0521, data zone: 01 03 01 01 00 01

Slave response, CAN ID: 0x0521, data zone: 01 83 02 02 EF

Note: The module slave address is 0x01, real-time distance value is 0x02EF, Convert to a decimal into 751mm。

Example3: Read the temperature data

Host sent, CAN ID: 0x0524, data zone: 04 03 01 02 00 01

Slave response, CAN ID: 0x0524, data zone: 04 83 02 01 2C

Note: The module slave address is 0x04, the real-time temperature value is 0x012C, converted to decimal into 30.0°C.

Example 4: Modify the slave address

Host sent, CAN ID: 0x0521, data zone: 01 06 02 00 00 05

Slave response, CAN ID: 0x0521, data zone: 01 86 02 00 00 05

Note: The module slave address is modified from 0x01 to 0x05.The new address will be used for the next communication, with a corresponding CAN ID of 0x0525.

**Example 5: Read Angle Level**

Host sent, CAN ID: 0x0525, data zone: 05 03 02 08 00 01

Slave response, CAN ID: 0x0525, data zone: 05 83 02 00 03

Note: The module slave address is 0x05, the read angle level is level 3

**Example 6: Set the range level**

Host sent, CAN ID: 0x0525, data zone: 05 06 02 1F 00 03

Slave response, CAN ID: 0x0525, data zone: 05 86 02 1F 00 03

Note : The module slave address is 0x05, set the range level is level 3, and the range is about 250cm.