

DYP
Smart Sensor

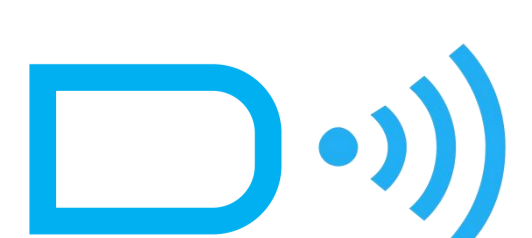

A21 SERIES SENSOR MODULE

DATASHEET



<https://dypsensoren.alibaba.com/>

SHENZHEN DIANYINGPU TECHNOLOGY Co.,LTD.

CONTENTS

01. Product Introduction	01
1.1 Overview.....	01
1.2 Functionality Abstracts.....	01
1.3 Product Advantages.....	02
1.4 Scope of Application.....	02
1.5 Basic Parameters.....	03
1.6 Mechanical Characteristics.....	04
1.7 Interface Definition.....	05
02. Limit Parameters	05
2.1 Rated Environmental Conditions.....	05
2.2 Rated Electrical Conditions.....	06
03. Module Selection Instructions	06
04. Reference Diagram Of Effective Range	15
05. Matters Needing Attention	16
06. Packaging Specification	17



1. Product introduction

1.1 Overview

The A21 module is an ultrasonic obstacle avoidance sensor designed based on robot automatic control application, focus on designing for problems on the current market ultrasonic sensor large blind spot, small measurement angle, long response time, poor installation adaptability and other problems ,the A21 module has a series of advantages like small blind spot, large measurement angle, short response time, the same frequency filtering interference, high installation adaptability, dust and waterproof, long life and high reliability.

The intelligent acoustic processing technology independently developed by our company can identify and filter the interference acoustic wave, and output data more stable and reliable,making the A21 module reduce the probability of same frequency ultrasonic interference to a certain extent, and meet the users' application needs for the complex environment in the filed of robot automatic control.

A21 module, hereinafter referred to as "module".

1.2 Functionality Abstracts

- Wide voltage power supply, working voltage:3.3~24V
- 3cm standard blind area(product blind area can up to 2.5cm minimum)
- The farthest range can be set, a total 5-level range of 50cm、 150cm、 250cm、 350cm and 500cm can be set through instructions.
- A variety of output modes are available,UART auto / controlled, PWM controlled, switch volume TTL level(3.3V), RS485,IIC,etc. Although the output mode is different, the function is exactly the same (UART controlled and PWM controlled power consumption can support ultra-low sleep power consumption $\leq 5\mu A$)
- The default baud rate is 115,200, Supports modification to 4800, 9600, 14400, 19200, 38400, 57600, 76800
- Ms-level response time, data output time can up to 13ms fastest
- Single and double angle can be selected, the double angle measurement areas has a wider range; single angle can support 4-level settings of 50° 、 55° 、 65° 、 70° to apply to different application scenarios; double angle can support 4-level settings of 50° 、 55° 、 60° 、 65° , double-angle vertical angle can support 4-level settings of 65° 、 70° 、 75° 、 90° to apply to different application scenarios
- Built-in noise reduction function which can support the 5-grade noise reduction level setting, suitable for battery power supply,short and long distance USB power supply, switch power supply and large noise power supply

- Intelligent acoustic wave processing technology, built-in intelligent algorithm to filters interference sound waves; When the same frequency interference is present in the detection environment, the "FFFE" data is output to make a prompt, which can identify the interference sound waves and automatically perform filtering, and the correct rate is increased by 80% in the same frequency interference environment
- LED working status indication, the red and blue LED is turned on when powered on and extinguished after initialization, indicating that the system is functioning properly
- Waterproof structure design, waterproof grade IP67
- Strong installation adaptability, open-hole installation design, the installation method is simple, stable and reliable
- Ultra-wide temperature design, Working temperature -25°C to $+65^{\circ}\text{C}$
- Electrostatic protection design, input and output interface with electrostatic protection devices, in line with IEC61000-4-2 standard

1.3 Product advantages

- Wide supply voltage
- Wide supply voltage
- Small blind spot
- The output method is optional
- Support range modification
- Support baud rate modification
- Support address modification
- Support angle setting
- Support the power supply noise reduction level setting
- Effectively reduce the probability of same frequency interference
- High waterproof grade
- Simple to install
- Wide working temperature
- Strong anti-static
- Standby ultra-low power consumption
- High measurement accuracy
- Data measurement is stable and reliable

1.4 Scope of application

- Robot avoidance and automatic control
- Horizontal ranging
- Parking Management System
- Object proximity and presence awareness

1.5 Basic parameters

Parameters	UART auto	UART controlled	PWM	Switch volume	RS485	IIC	CAN	Unit	Note
Working voltage	3.3~24							V	DC
Standby current	-	≤5	≤5	-	7000	6000	7000	uA	(1)
Average working current	≤6	≤6	≤6	≤6	≤10	≤8	≤10	mA	(2)
Blind area distance	≤3							cm	
Flat object range	3~500							cm	(3)
Output response time	100~130	8~140	<7	1500~2000	15~750	15~140	15~750	ms	(4)
Power working hours	≤1000							ms	
Working period	100~130	Controlled	Controlled	100~130	Controlled	Controlled	Controlled	ms	
Output method	automatic	Controlled	Controlled	automatic	Controlled	Controlled	Controlled	-	
Measurement accuracy at room temperature	1+(S*0.3%)							cm	(3)
Temperature compensation	Compensate							-	
Single angle	50~70							°	(5)
Double angle	Level 50~65							°	(6)
	Vertical 65~90							°	(7)

Remarks :

(1)The module exceeds 5S does not receive the control instruction will enter a low power consumption dormant state, when the power consumption current is the standby power consumption current;

(2)Typical data obtained by testing with temperature 25° C, humidity 65% RH, power supply 12V, and 100ms working cycle;

- (3)The temperature is 25° C, the humidity is 65% RH, the measured object is a 50cm×60cm flat carton, and the transducer should be as vertical as possible. S represents the measurement distance;
- (4)The output response time is 0.5~5 meter range test, the shorter the range, the faster the response time.
- (5)Test data for single-angle modules,The measured object is the reference data obtained from the test of φ75mm×100cm white PVC pipe with a distance of 100cm.
- (6)The center line of the two probes of the double-angle module is arranged horizontally with the ground, The measured object is the reference data obtained from the test of φ75mm×100cm white PVC pipe with a distance of 100cm.
- (7)The center line of the two probes of the double-angle module is arranged vertically with the ground, The measured object is the reference data obtained from the test of φ75mm×100cm white PVC pipe with a distance of 100cm.

1.6 Mechanical characteristics

Product structure size (mm-inch) :

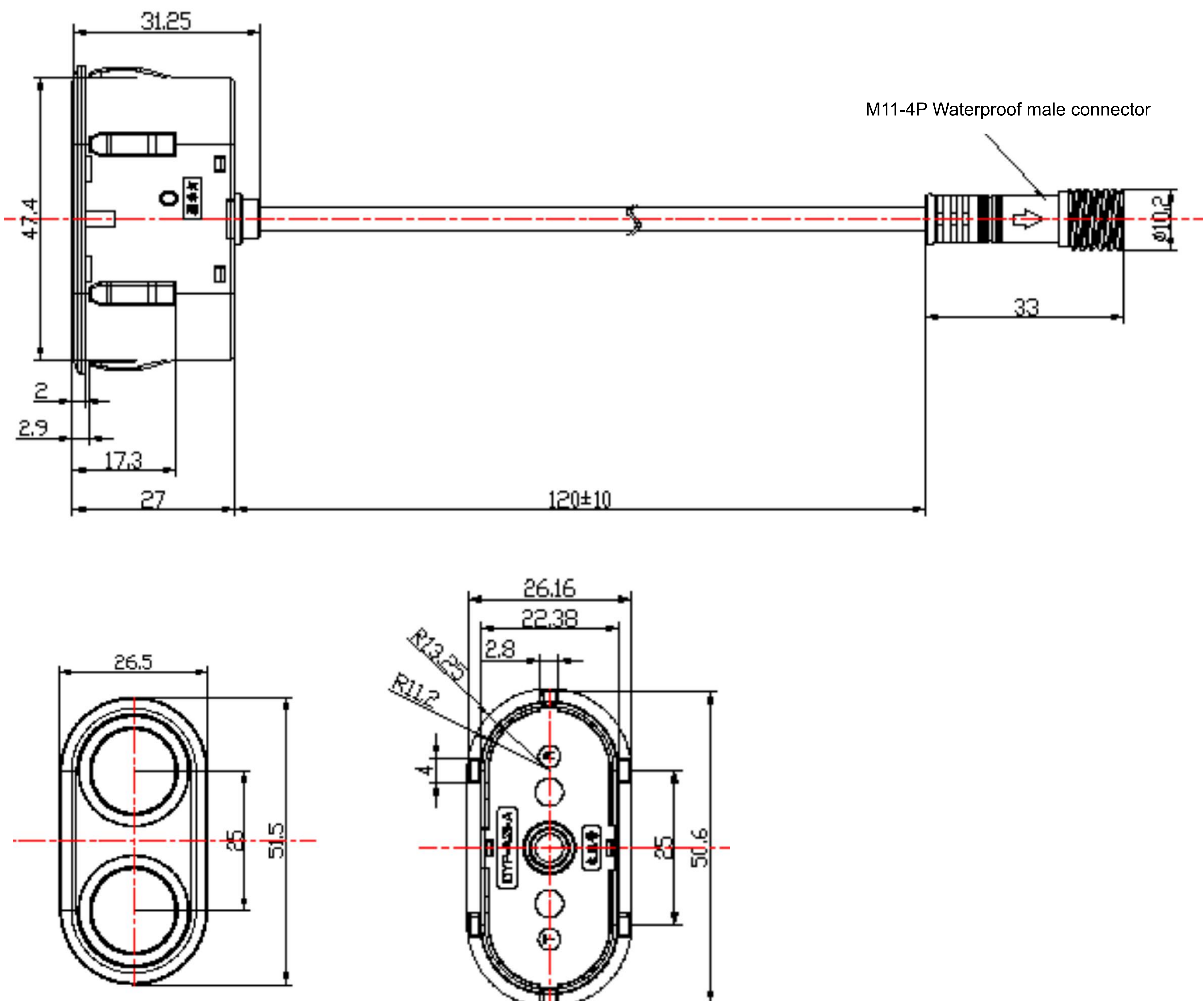

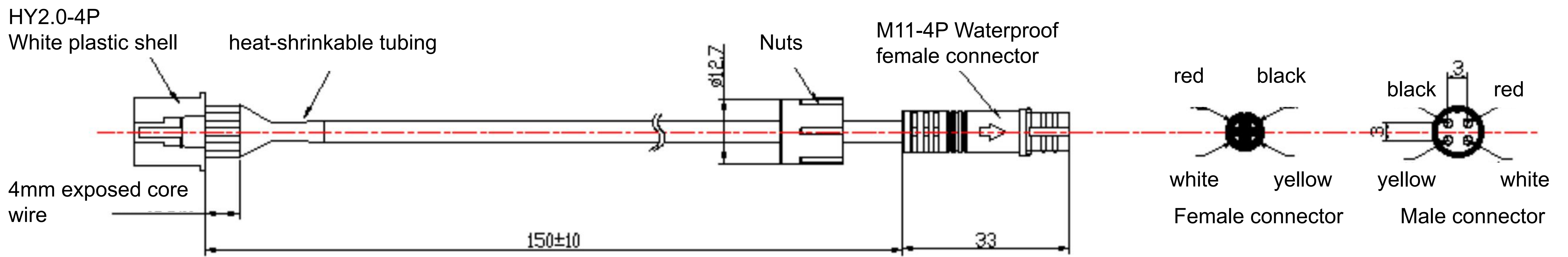

Wire:24644C*24AWG, black PVC core: red, black, yellow and white OD:4.0 mimeographfont

Recommendations of installing the opening:

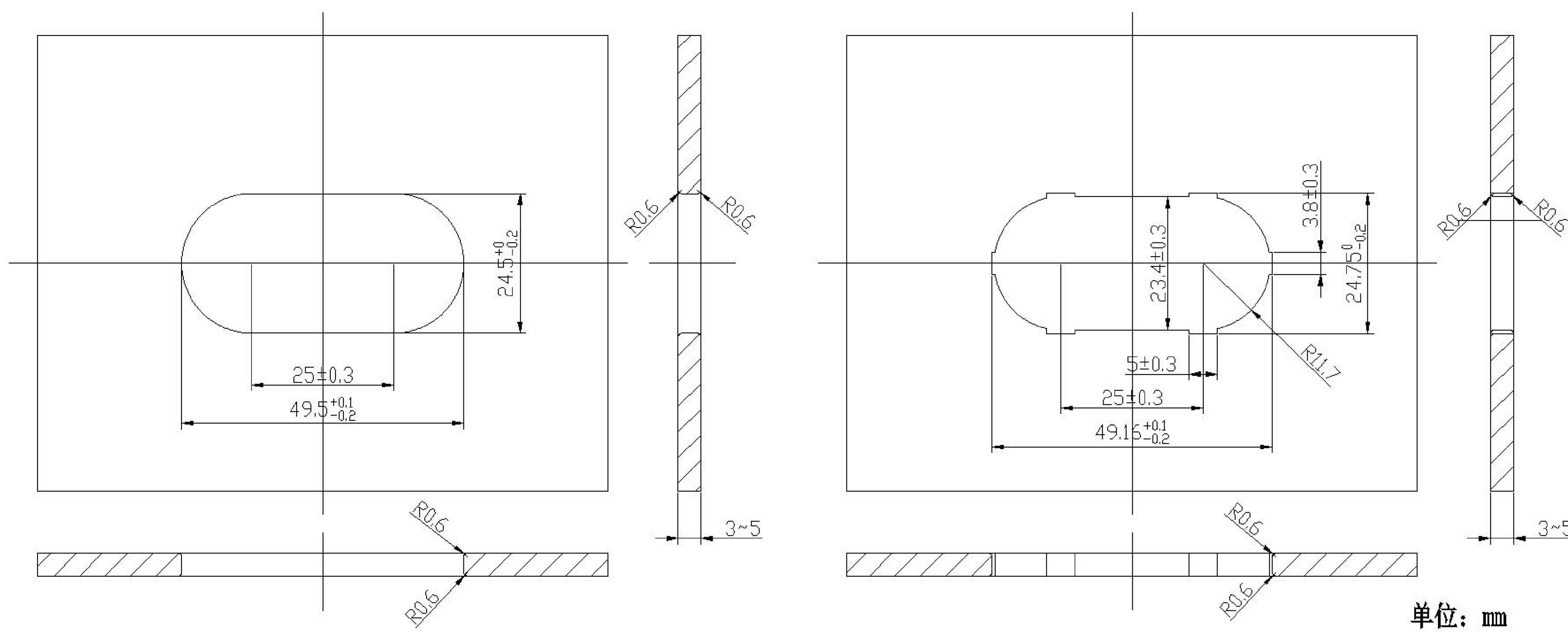

1.7. Interface definition

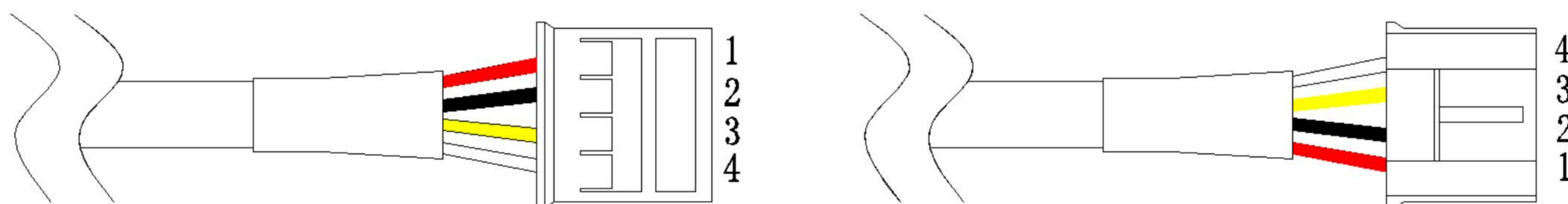

PIN #	PIN name	PIN description	Remarks
1	VCC	Power input PIN	
2	GND	Ground	
3	RX/B	Function PIN	(1)
4	TX/A	Function PIN	(1)

Remarks:

(1) Lead wire, pin function and output mode of product model correspond one-to-one, and cannot coexist with other output modes.

2.Limit parameters

2.1.Rated environment conditions

Item	Minimum	Typical value	Maximum	Unit	Remark
Storage temperature	-30	25	80	°C	
Storage humidity		65%	90%	RH	(1)
Operating temperature	-25	25	65	°C	
Operating humidity		65%	80%	RH	(1)

Remark:

(1) a. When the ambient temperature is 0-39° C, the maximum humidity is 90% (non-condensing)

(2) b. When the ambient temperature is 40-50° C, the highest humidity is the highest humidity in nature at the current temperature (no condensation)

2.2.Rated electrical conditions

Parameter	Specification			Unit	Remarks
	Minimum	Typical value	Maximum		
Operating voltage	3.3	12	24	V	
Peak current			150	mA	
Input ripple			50	mV	Peak to peak
Input noise			100	mV	Peak to peak
ESD			±4K/±8K	V	(1)

Remarks: (1) The connecting leads and pins conform to the IEC61000-4-2 standard

3. Model selection description

The output format of this series of ranging modules is divided into six formats and two angles. Users can choose the corresponding model according to the actual application. If there are special requirements that need to modify the response time, angle, communication agreement, etc., you need to communicate with our FAE engineers during purchasing.

Serial	A21series model	Feature	Output method
1	DYP-A21AYYUW-V1.0	Single angle	UART auto output
2	DYP-A21AYYTW-V1.0		UART controlled output
3	DYP-A21AYYMW-V1.0		PWM controlled output
4	DYP-A21AYYGDW-V1.0		TTL switch output
5	DYP-A21AYYCW-V1.0		IIC output
6	DYP-A21AYY4W-V1.0		RS485 output
7	DYP-A21AYYCAW-V1.0		CAN output
8	DYP-A21AYYPW-V1.0		PNP switch output
9	DYP-A21AYYNW-V1.0		NPN switch output
10	DYP-A21BYUW-V1.0	Double angle	UART auto output
11	DYP-A21BYTW-V1.0		UART controlled output
12	DYP-A21BYMW-V1.0		PWM controlled output
13	DYP-A21BYGDW-V1.0		TTL switch output
14	DYP-A21BYCW-V1.0		IIC output
15	DYP-A21BY4W-V1.0		RS485 output
16	DYP-A21BYCAW-V1.0		CAN output
17	DYP-A21BYYPW-V1.0		PNP switch output
18	DYP-A21BYYNW-V1.0		NPN switch output

4. Reference diagram of the effective detection range

4.1. Single angle series

4.1.1 The tested object is PVC material of white cylindrical tube, height of 100cm and diameter of 7.5cm.

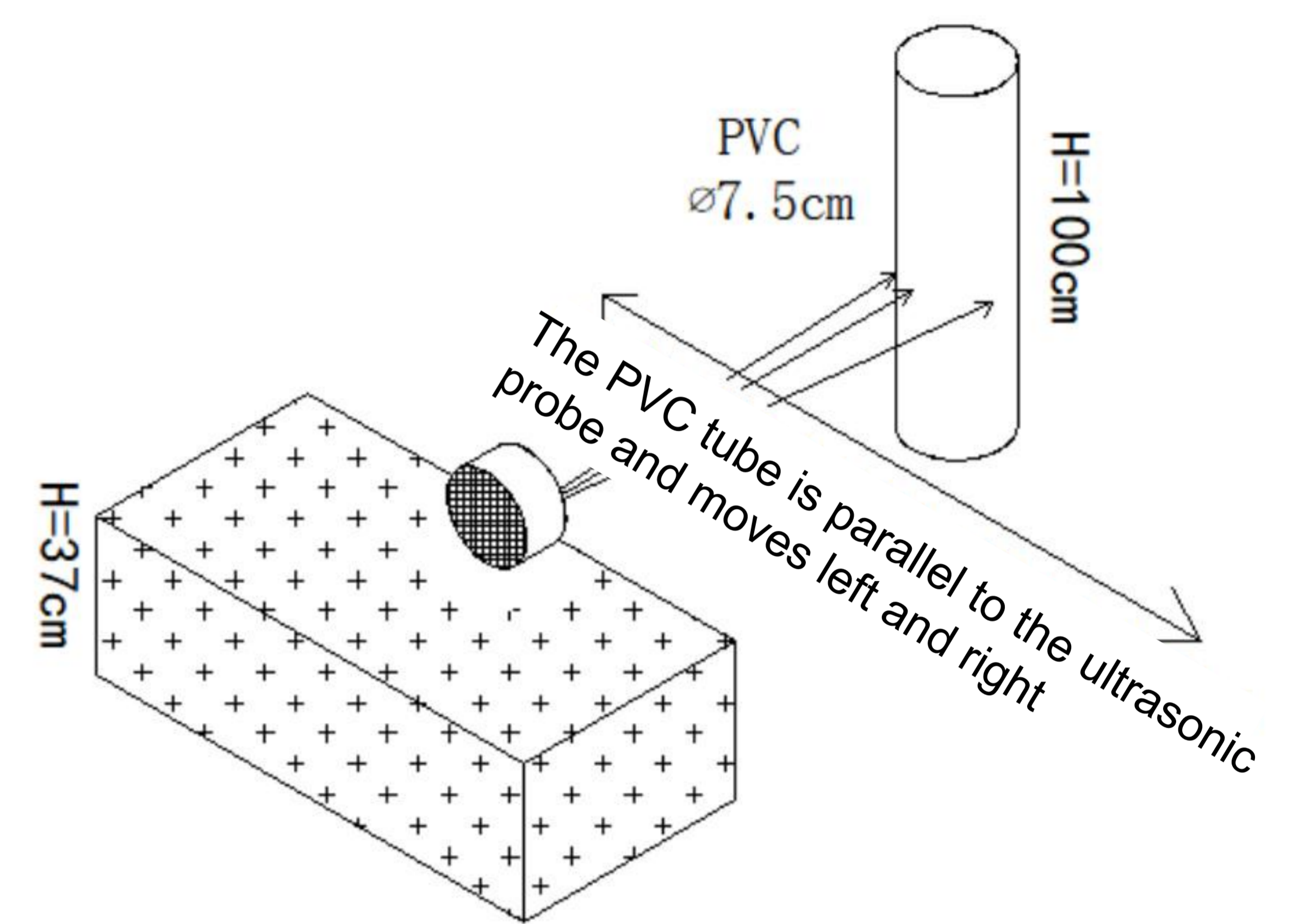
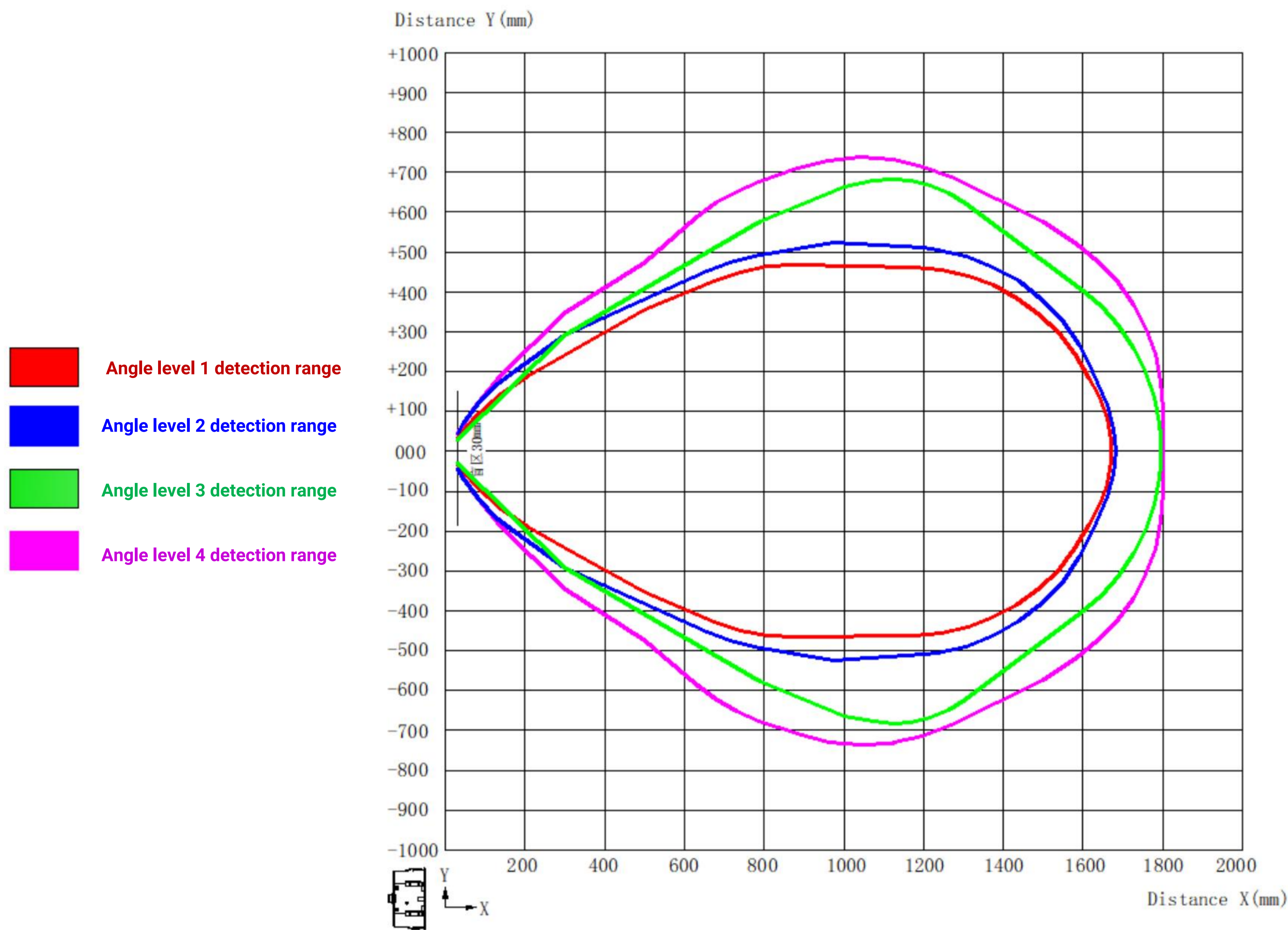

4.1.2 The object to be tested is a "corrugated cardboard box" perpendicular to the 0 degree central axis, with a length*width of 60cm*50cm.

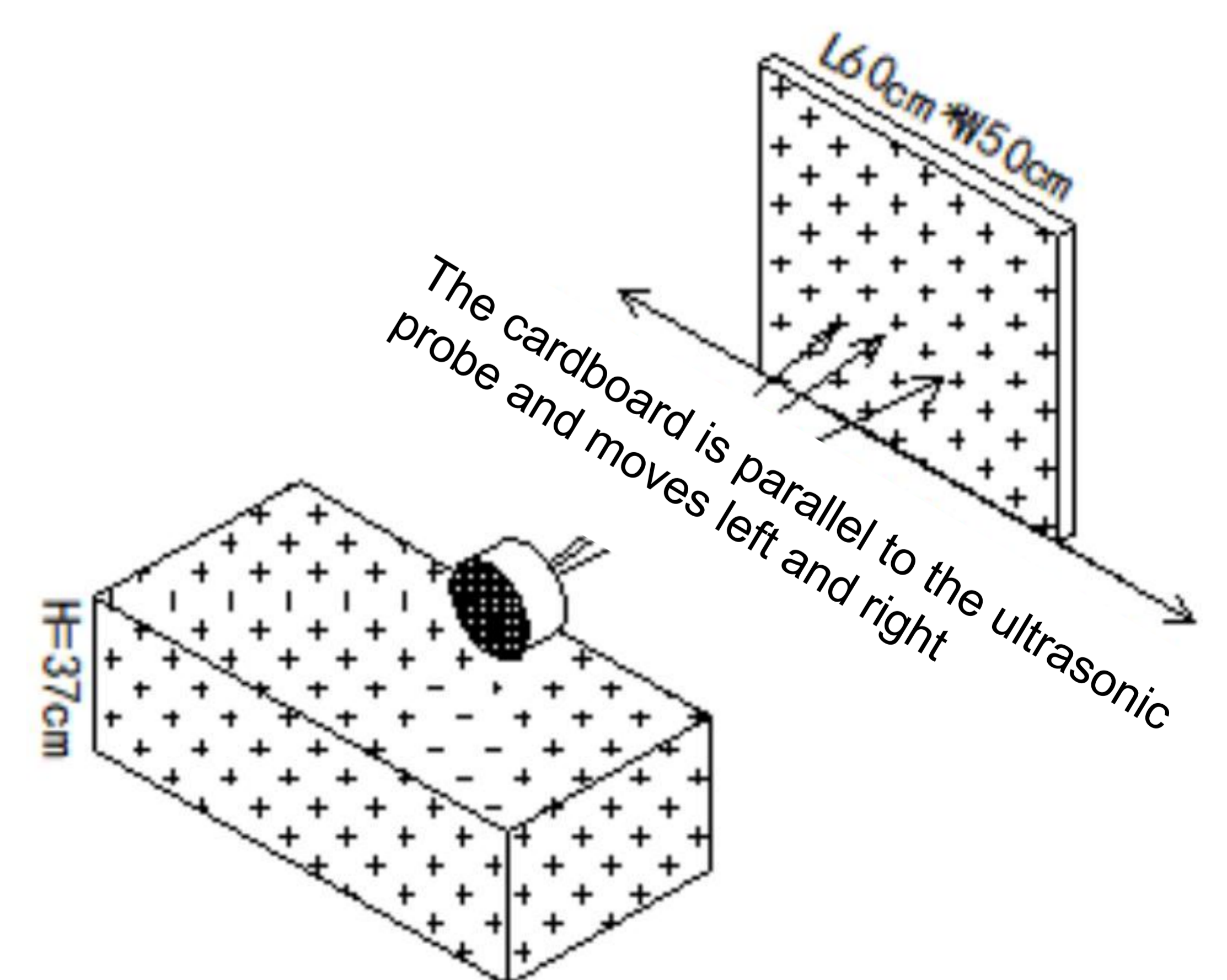
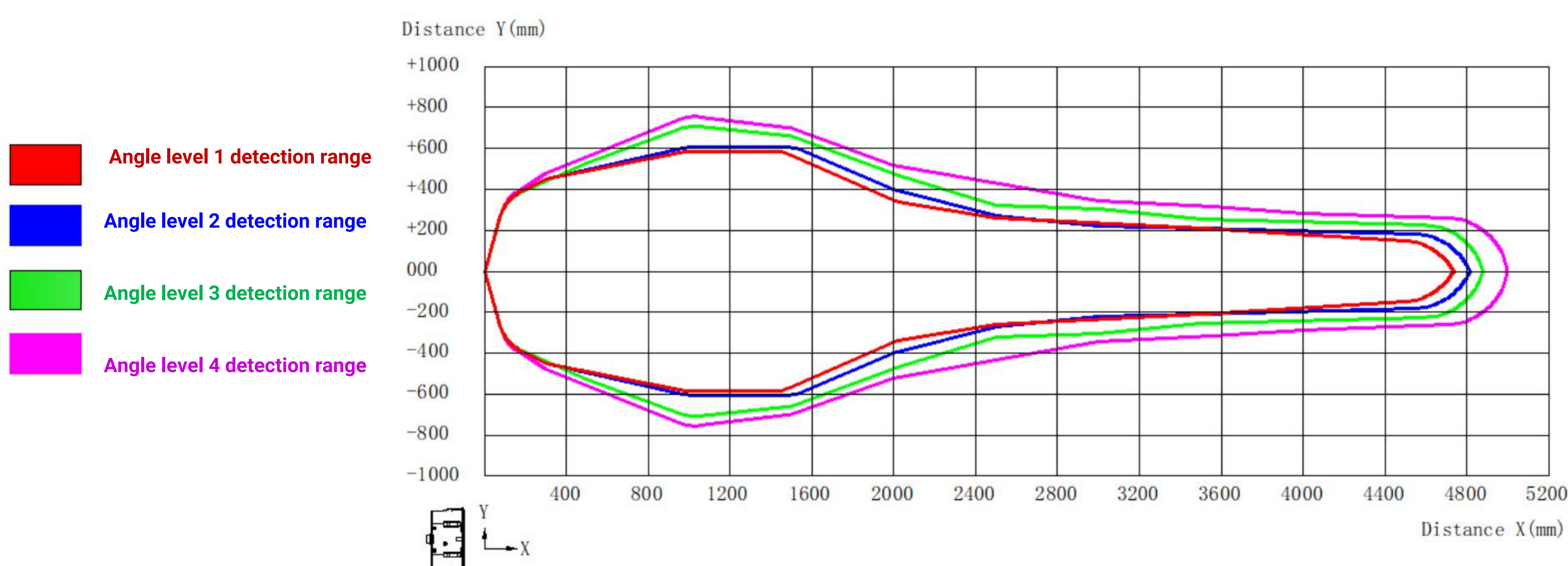

4.1.3 The object to be tested is a "corrugated box" tangent to the arc, length * width is 60cm * 50cm.

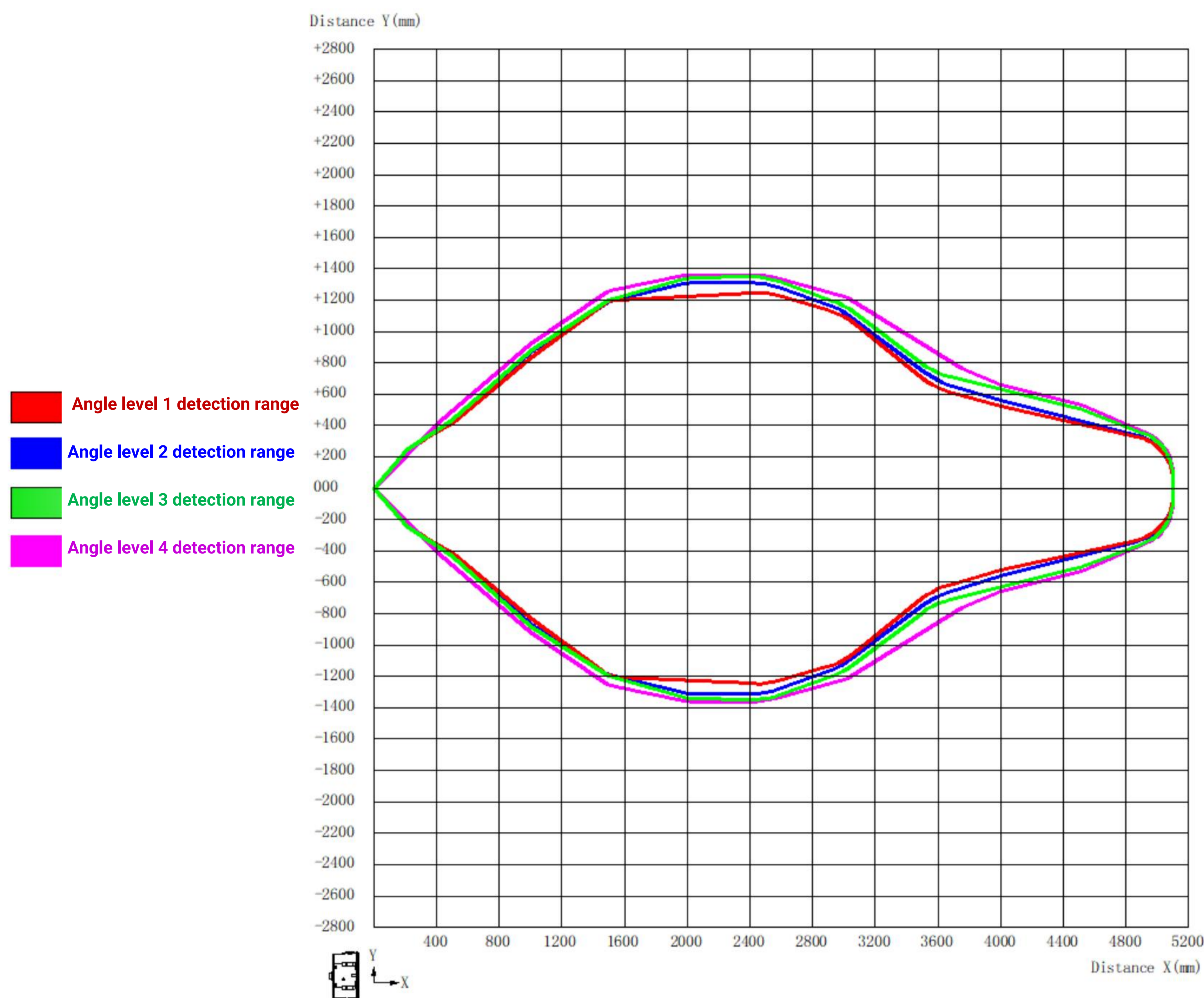

The cardboard moves in an arc with the ultrasonic probe as the center

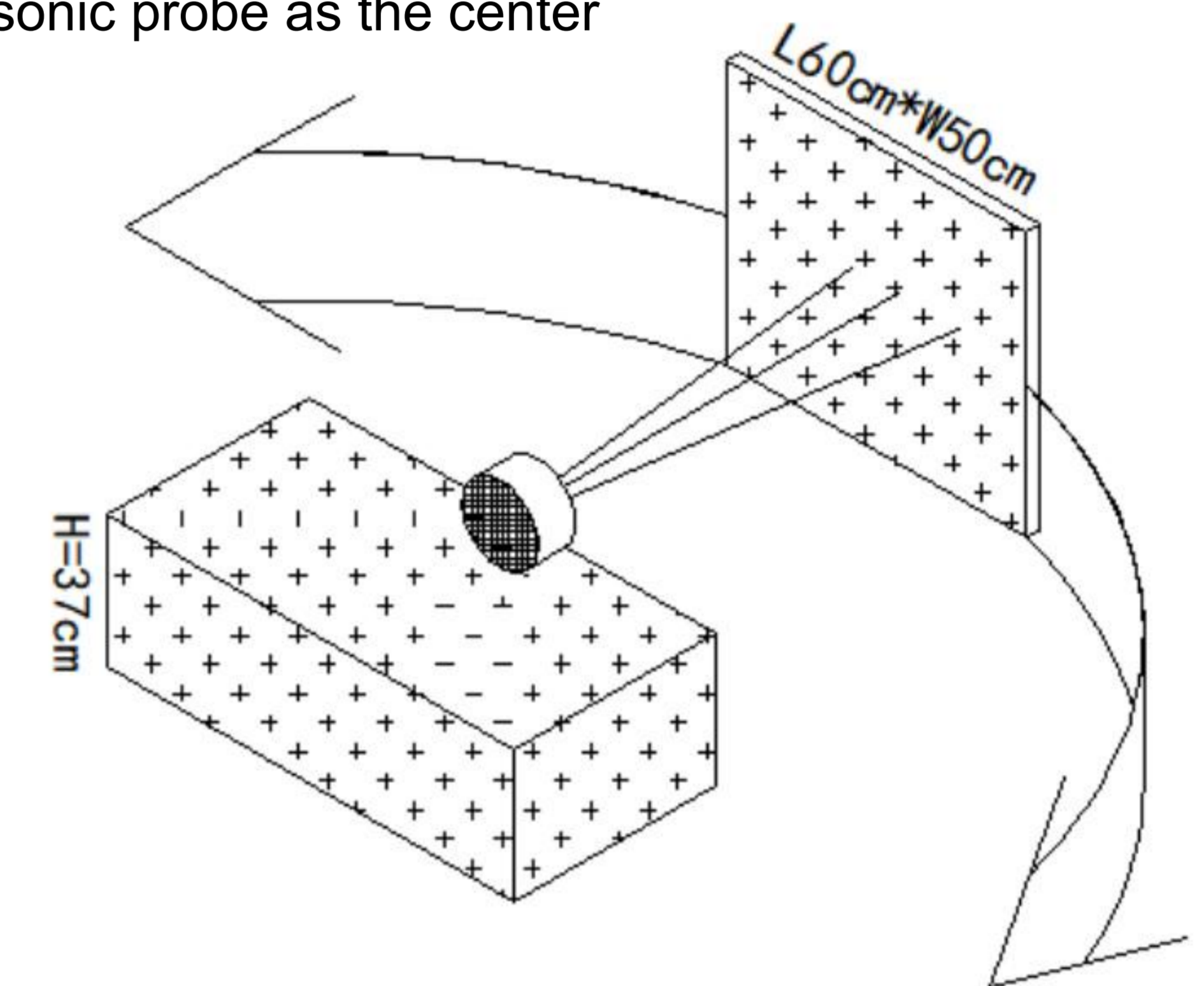

4.2 Dual Angle Series

4.2.1 Horizontal angle: The center line of the two probes is horizontal to the ground.

4.2.1 (1) The object to be tested is PVC material of white cylindrical tube, with a height of 100 cm and a diameter of 7.5 cm.

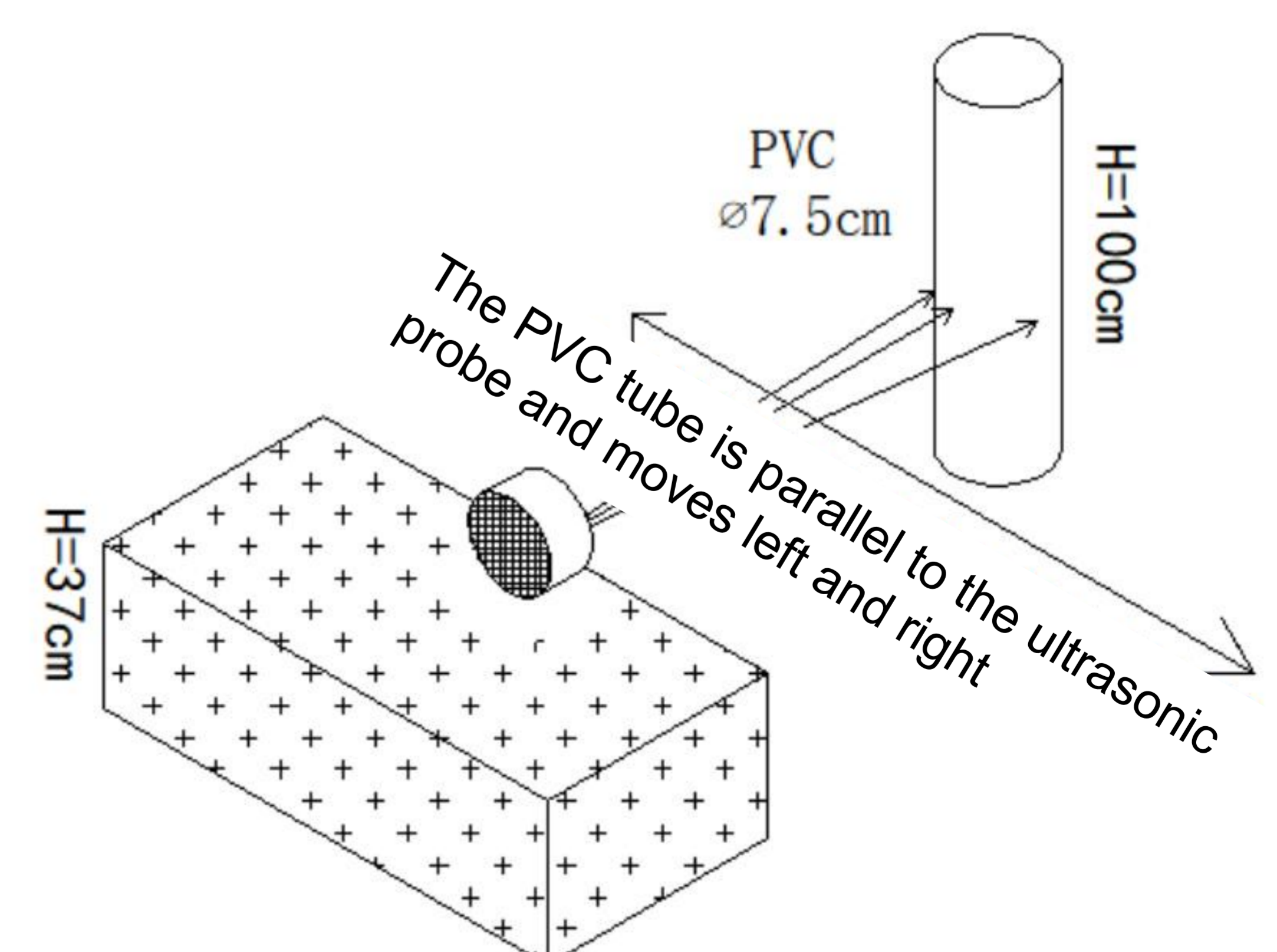
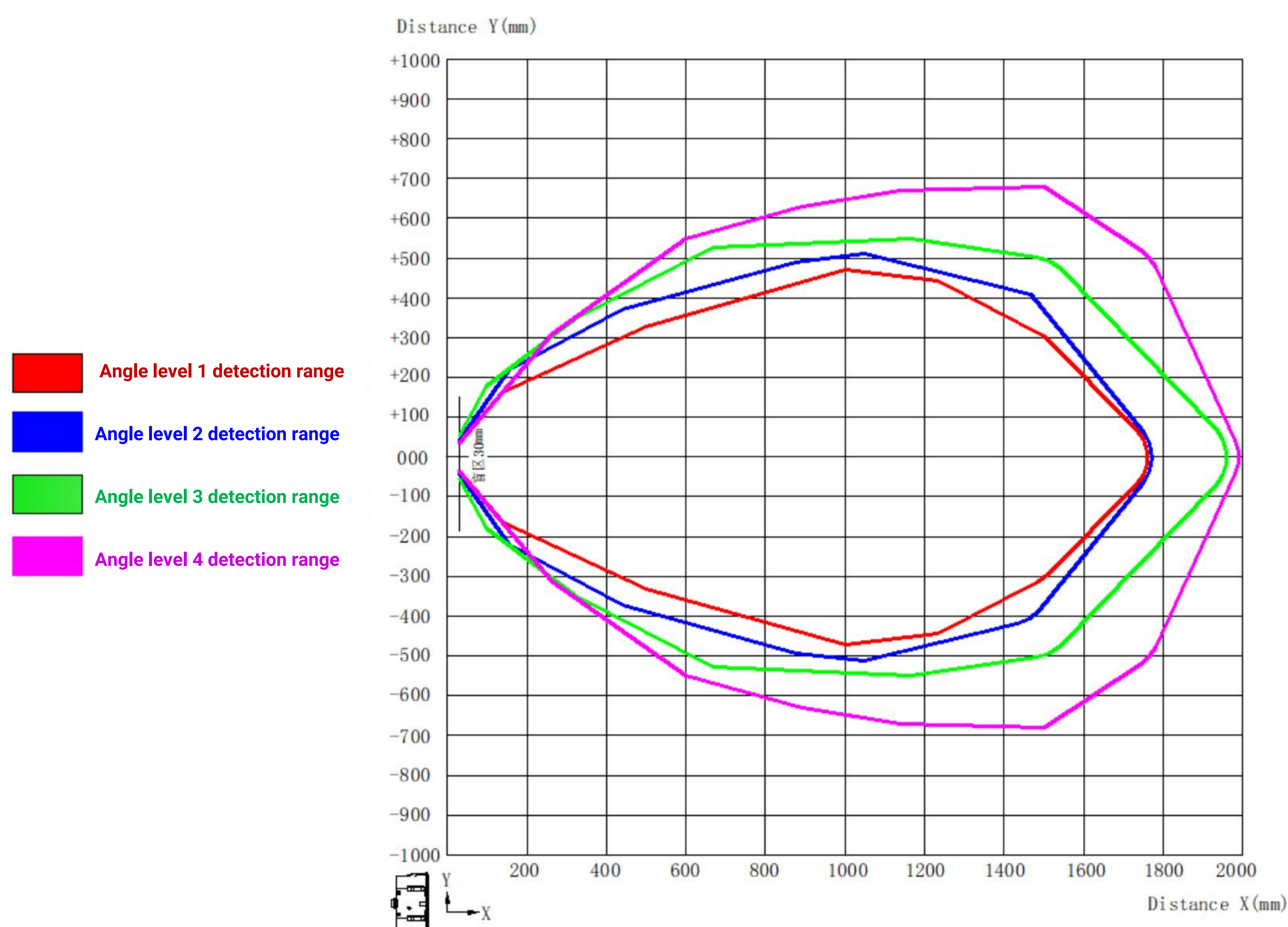

4.2.1 (2) The object to be tested is a "corrugated cardboard box" perpendicular to the 0 degree central axis, with a length*width of 60cm*50cm.

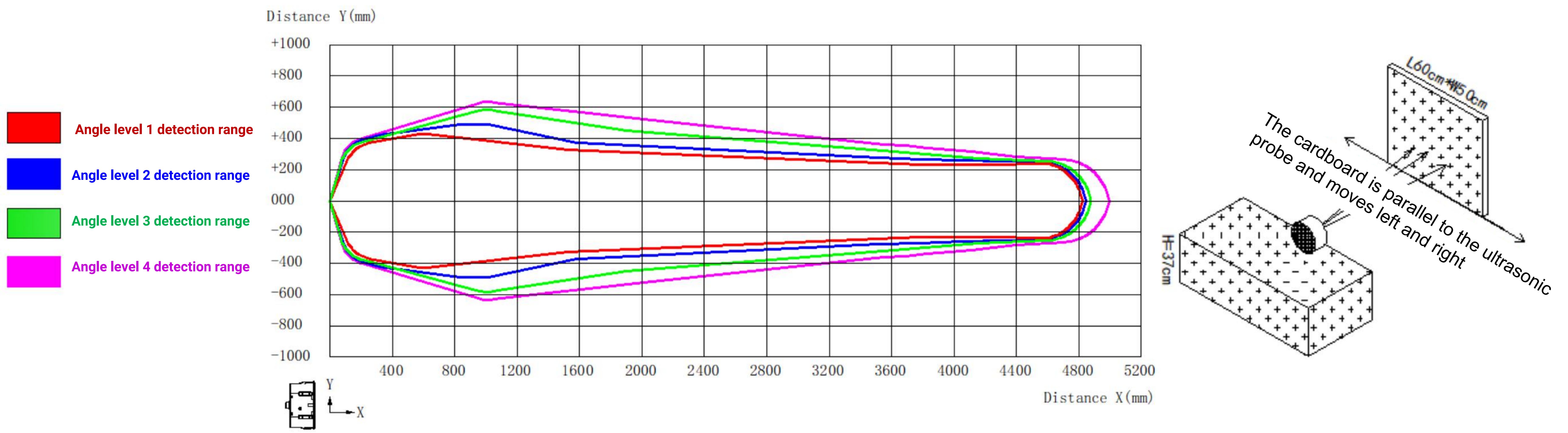

4.2.1 (3) The object to be tested is a "corrugated box" tangent to the arc, length * width is 60cm * 50cm.

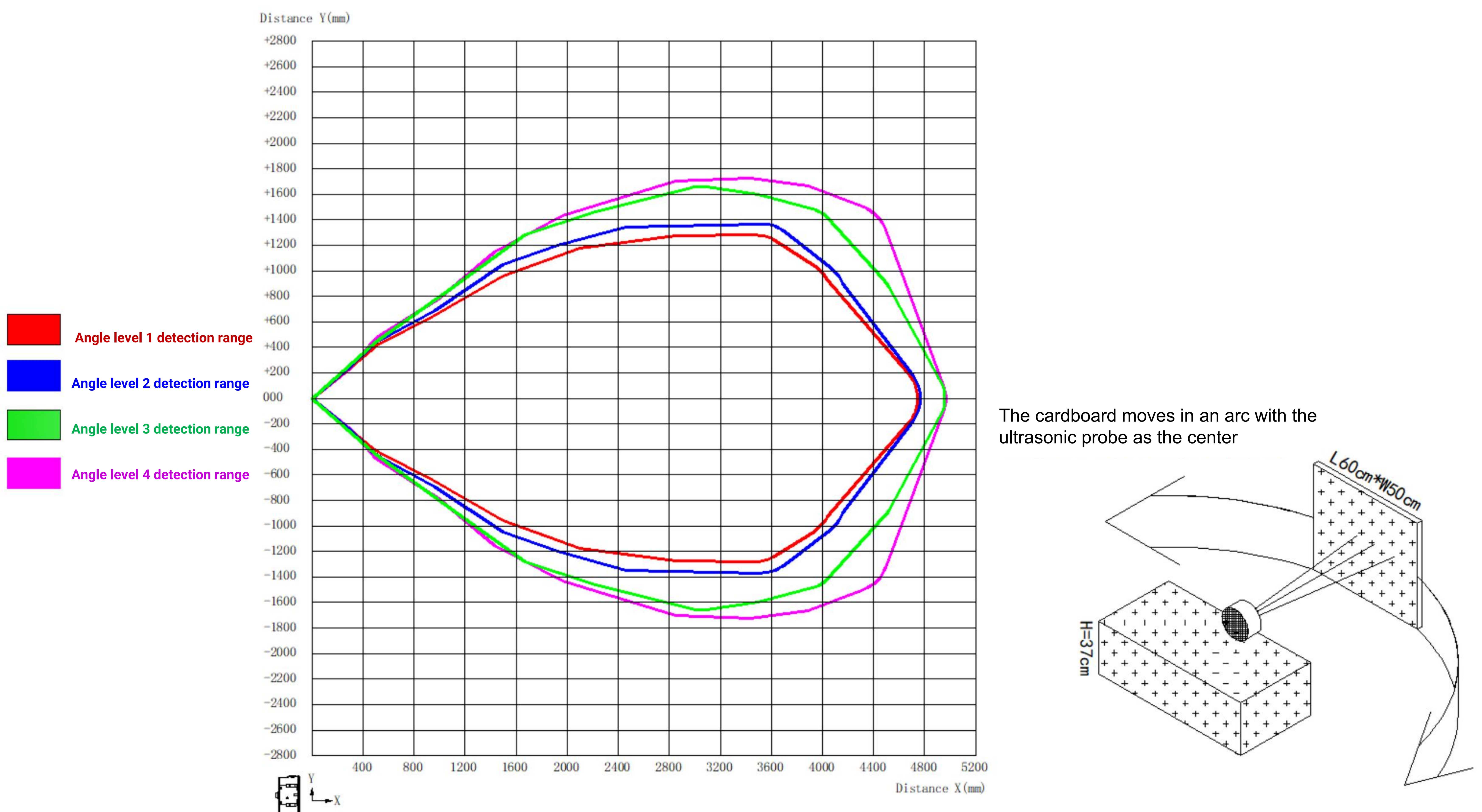

4.2.2 Vertical angle: The center line of the two probes is arranged perpendicular to the ground.

4.2.2 (1) The object to be tested is PVC material of white cylindrical tube, with a height of 100 cm and a diameter of 7.5 cm.

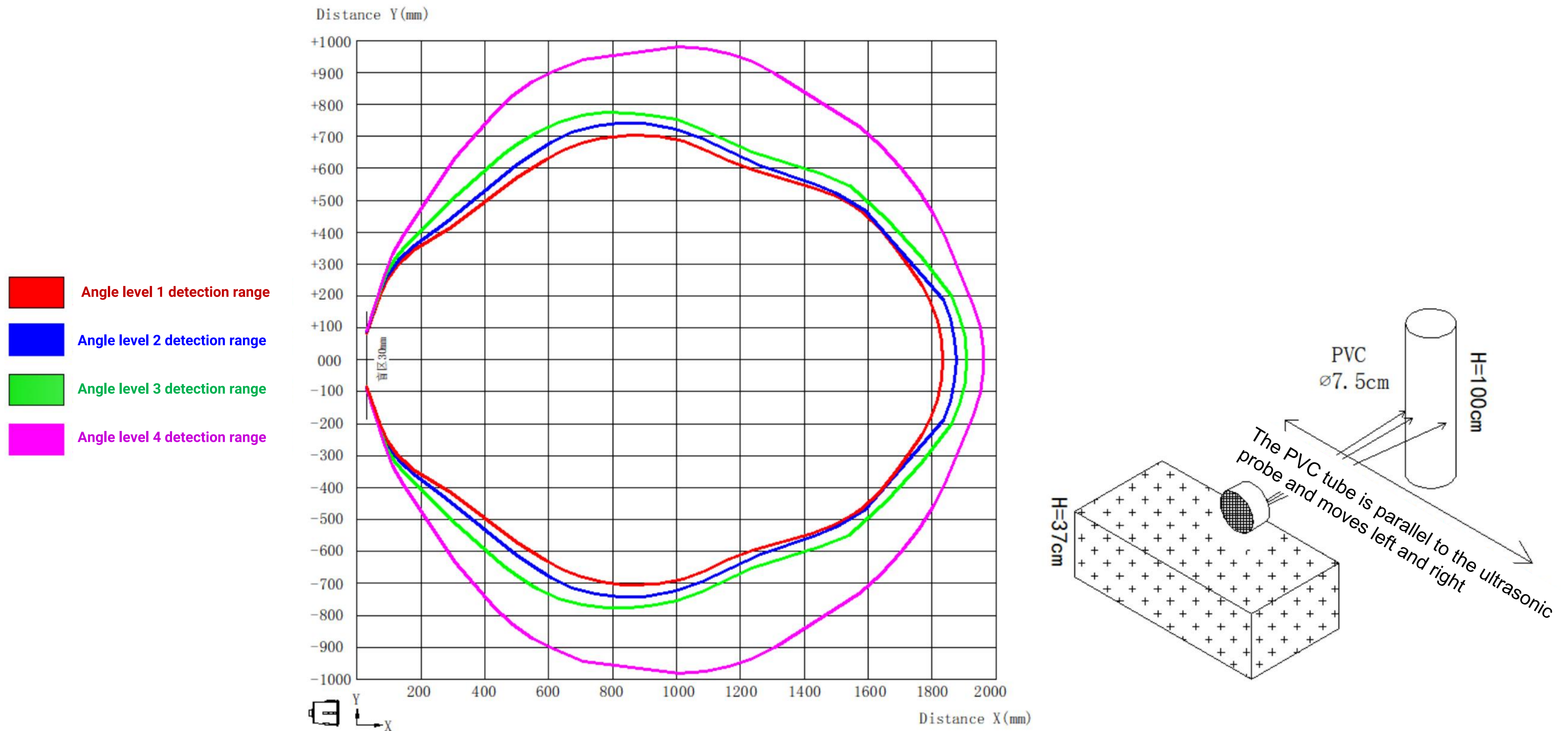

4.2.2 (2) The object to be tested is a "corrugated cardboard box" perpendicular to the 0 degree central axis, with a length*width of 60cm*50cm.

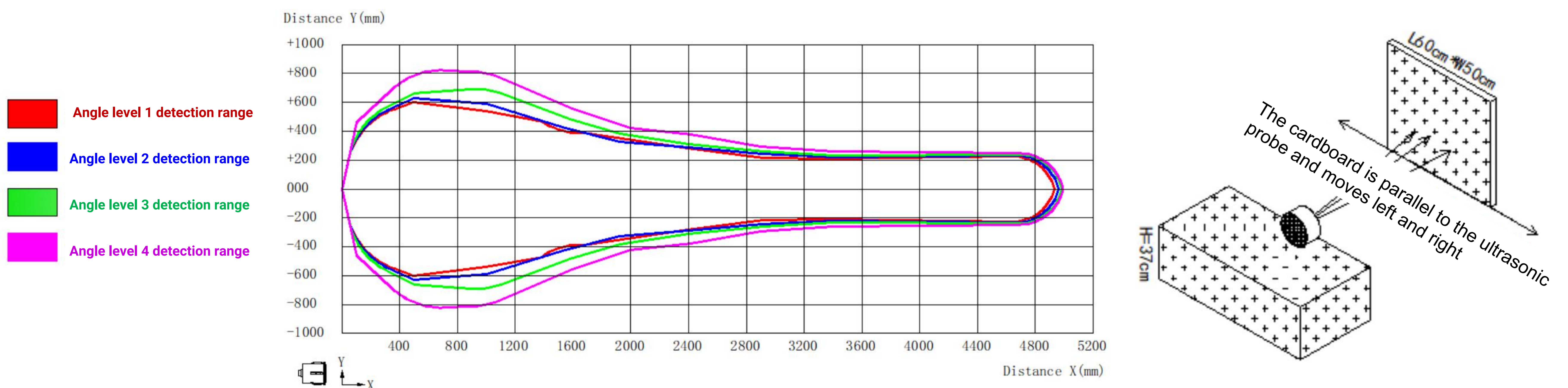

4.2.2 (3) The object to be tested is a "corrugated box" tangent to the arc, length * width is 60cm * 50cm.

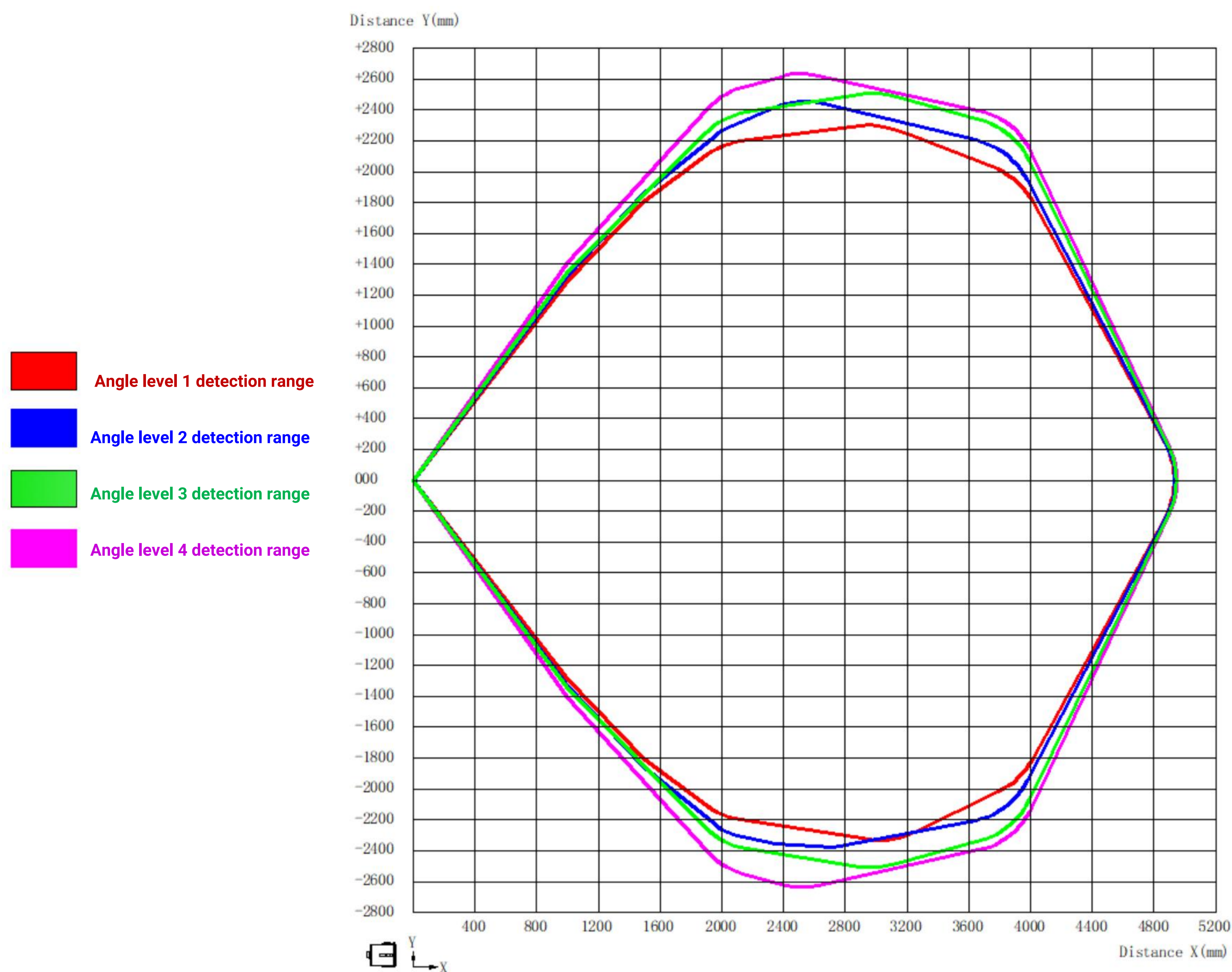

The cardboard moves in an arc with the ultrasonic probe as the center

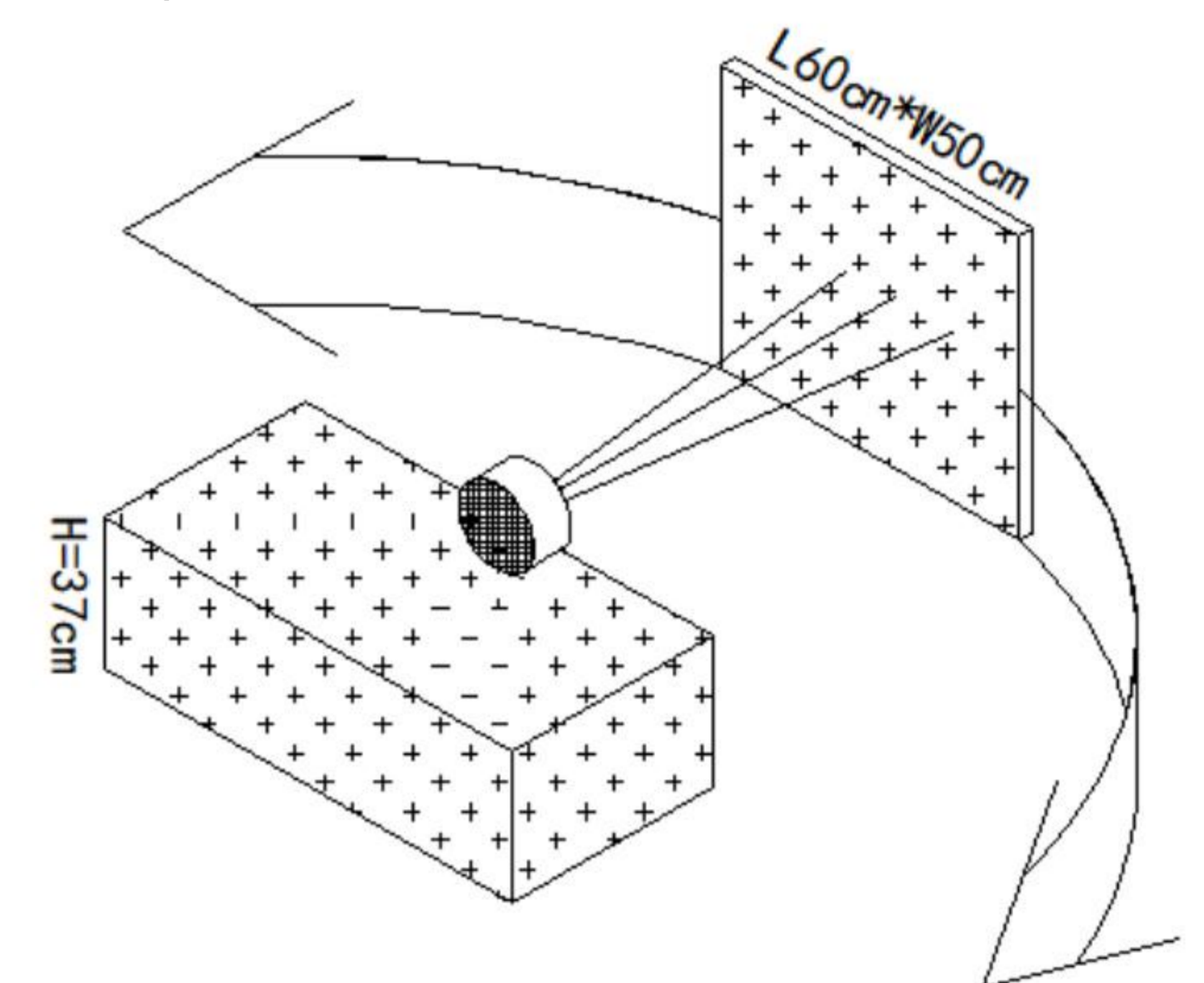

Note: The above data is the test data of Dianyingpu Technology Laboratory. In actual use, various factors such as product installation method and usage environment may differ from laboratory data. Please refer to the actual application environment test.

5. Matters needing attention

1. The company reserves the right to change this document and update the functions without notice;
2. Please pay attention to the structural tolerances when designing. Unreasonable structural design may cause transient abnormalities in module functions;
3. Please pay attention to the evaluation of electromagnetic compatibility when designing. Unreasonable system design may cause abnormal module function;
4. When the boundary application of the product limit parameter is involved, you can contact our FAE to confirm the relevant precautions.
5. The response time and same-frequency interference of this product are configured in common scenarios, and can be improved in special scenarios. You can contact our FAE to communicate with related matters

6. Packaging specification

1. The default is Denyong's conventional packaging method;
2. Packaging materials can be customized according to customer IQC related standards;
3. The container transportation method needs to adopt the staggered consolidation method, and at the same time, the outer edge of the single stack needs to be wrapped with a reinforced gusset to provide sufficient support.