



深圳飞特模型有限公司

SHENZHEN FEETECH RC MODEL CO.,LTD.

产品规格书

PRODUCT SPECIFICATION

客 户 (CUSTOMER) :
型 号 (MODEL) : FT935BL-C001
名 称 (PRODUCT NAME) : 7.4V 35kg. cm PWM数码金属壳钛齿轮无刷舵机
版 本 (EDITION) : A/0

在您下单采购本产品之前, 请阅读本规格书并在下列确认栏内签字回传。

Sign back before you place an order to purchase this product,
please read this specification and in the following admit column.

飞特确认/ FEETECH APPROVED

编写 EDIT	审核 CHECKED	确认 APPROVED
颜永杰	巫耿炎	

客户确认/CUSTOMER APPROVED

审阅 REVIEW	审核 CHECKED	确认 APPROVED

地址: 广东省深圳市龙岗区横岗镇六约埔厦路60号2楼

ADD: Floor 2, No 60, PuXia Road, LiuYueHengGang Town, Long Gang District,
ShenZhen, 518173, China

电话/Tel: 0755-89335266 网址/Website: www.feetech.cn

		深圳飞特模型有限公司 SHENZHEN FEETECH RC MODEL CO., LTD.		版本EDITION: A/0
型号/MODEL: FT935BL-C001		产品规格书 PRODUCT SPECIFICATION		日期/Date: 2023-08-10
页 码 Page: 3/7				
1. 使用环境条件 Apply Environmental Condition:				
No.	项目(Item)		规格(Specification)	
1-1	保存温度Storage Temperature Range		-30℃~80℃	
1-2	运行温度Operating Temperature Range		-20℃~60℃	
2. 测试环境 Standard Test Environment:				
No.	项目(Item)		规格(Specification)	
2-1	温度 Temperature Range		25℃ ±5℃	
2-2	湿度 Humidity Range		65%±10%	
3. 安全特性与认证 Secure Performance and Certificate				
No.	项目/Item	认证Certificate	备注 (remarks)	
3-1	ASTM F963	No	美国玩具检测标准	
3-2	EN71	No	欧盟市场玩具类产品的规范标准	
3-3	FCC	No	对电子、电器中的电磁干扰，管理和控制无线电频率范围，保护电信网络、电器产品的正常工作。	
3-4	EMC	Yes	对任何的物质而言，不给其无法容许的电磁干扰波，且在电磁环境中还需能具有满足其功能的机器，装置或系统的能力	
3-5	ROHS	Yes	电子，电器设备中对人体有害物质的含量。	
3-6	REACH	NO	欧盟法规《化学品的注册、评估、授权和限制》	
4. 外观检查 Appearance Inspection:				
No.	项目(Item)		规格(Specification)	
4-1	外观尺寸OutlineDrawing		尺寸见附件(第12项) See the appendix	
4-2	外观Appearance		无损坏，不允许影响功能 No damage and mustn't affect functions.	
5. 电气特性 Electrical Specification				
No.	项目(Item)	规格(Specification)	规格(Specification)	
5-1	工作电压 Operating Voltage	6V	7.4V	
5-2	空载速度 ±10% No Load Speed	0.111sec/60° (90RPM)	0.09sec/60° (110RPM)	
5-3	空载电流 ±10% Running Current (no load)	260mA	280mA	
5-4	堵转扭力 Stall Torque (at locked)	30kg. cm	35kg. cm	
		417.35oz. in	486.91oz. in	
5-5	堵转电流 ±10% Stall Current (at locked)	5.5A	6.5A	
5-6	静态电流 ±10% Idle Current (at stopped)	36mA	36mA	
5-7	工作电压范围 Input Voltage Range	6V-8.4V		
5-8	额定负载 Rated Torgue	7.5kg. cm	8.5kg. cm	
5-9	额定电流 Rated Current	1300mA	1600mA	
5-10	Kt常数	5.38kg. cm/A		

	深圳飞特模型有限公司 SHENZHEN FEETECH RC MODEL CO., LTD.	版本EDITION: A/0
型号/MODEL: FT935BL-C001	产品规格书 PRODUCT SPECIFICATION	日期/Date: 2023-08-10
		页 码 Page: 4/7

6 机械规格 Mechanical Specification:

No.	项目 (Item)	规格 (Specification)	备注 (remarks)				
6-1	外观尺寸 Size	40X20X36.7	见图纸See drawings				
6-2	机构极限角度 Limit Angle	200°					
6-3	外壳材质 Case material	Aluminum					
6-4	齿轮材质 Gear material	钛齿 TITANIUM GEAR					
6-5	轴承类型 Bearing type	滚珠轴承 Ball bearings					
6-6	角度传感器 Angle Sansor	类型Type	12 Bit Magnetic Encoded				
		角度 Angle	360°				
		寿命 Life	No Limit				
6-7	连接器和电缆 Connector and Cable	类型 Type	JR				
		Material材质	铁氟龙				
		线长度 Length	35CM				
		引脚定义 Pin Definition	<table border="1"> <tr> <td>1</td> <td>Signal</td> </tr> <tr> <td>2</td> <td>Vcc</td> </tr> <tr> <td>3</td> <td>GND</td> </tr> </table>	1	Signal	2	Vcc
1	Signal						
2	Vcc						
3	GND						
							
6-8	重量The Weight	73 ± 1g					
6-9	出力轴 Horn Type	24T/5.75mm					
6-10	减速比Gear Ratio	1/280					
6-11	齿轮虚位Back Lash	≦ 0.5°					
6-12	摇臂虚位 The rocker phantom	0°					
6-13	出力轴螺丝 The rocker screw	M3X6					
6-14	马达Motor	Brushless Motor					

7 控制特性Control Specification:

No.	项目 (Item)	规格 (Specification)	备注 (remarks)
7-1	控制信号 Command Signal	Pulse width modification	
7-2	控制系统类型 Control System Type	Digital comparator	
7-3	操作角度 Operating Travel	120° ± 5° (at 900→2100 μ sec)	180° ± 5° (at 500→2500 μ sec)
7-4	两边角度差 Left&Right Travelling Angle deviation	≦ 5°	
7-5	回中差 Centering Deviation	≦ 1°	
7-6	中立位置 Neutral Position	1500 μ sec	
7-7	死区宽度 Dead Band Width	≦ 4 μ sec	
7-8	旋转方向 Rotating Direction	顺时针 clockwise (在500→2000 μ sec)	
7-9	脉波宽度范围 Pulse Width Range	500→2500 μ sec	
7-10	电子保护 Electronic Protection	无	

	深圳飞特模型有限公司 SHENZHEN FEETECH RC MODEL CO., LTD.	版本EDITION: A/0
---	--	-------------------

型号/MODEL:
FT935BL-C001

产品规格书
PRODUCT SPECIFICATION

日期/Date:
2023-08-10

页 码 Page: 5/7

8 可靠性测试 Reliability Testing

No.	项目 (Item)	规格 (Specification)	备注 (remarks)
8-1	负载寿命测试Life test	>200000次	正转60度0.25S, 停0.5S, 反转60度0.25S, 停0.5S为一次, 持续循环工作, 负载1/5堵转扭矩/1/2的空载速度, 测试工作电压7.4V。
8-2	马达噪音The motor noises	45±5dB	环境噪音40-45 dB 距离噪音仪30cm处测试
8-3	舵机噪音Steering gear noises	65±5dB	环境噪音40-45 dB 距离噪音仪30cm处测试 / 测试电压7.4V-1/3空载速度
8-4	防水性能Waterproof performance	IP54	

9 外观尺寸 Outside Dimension(单位Unit: mm)

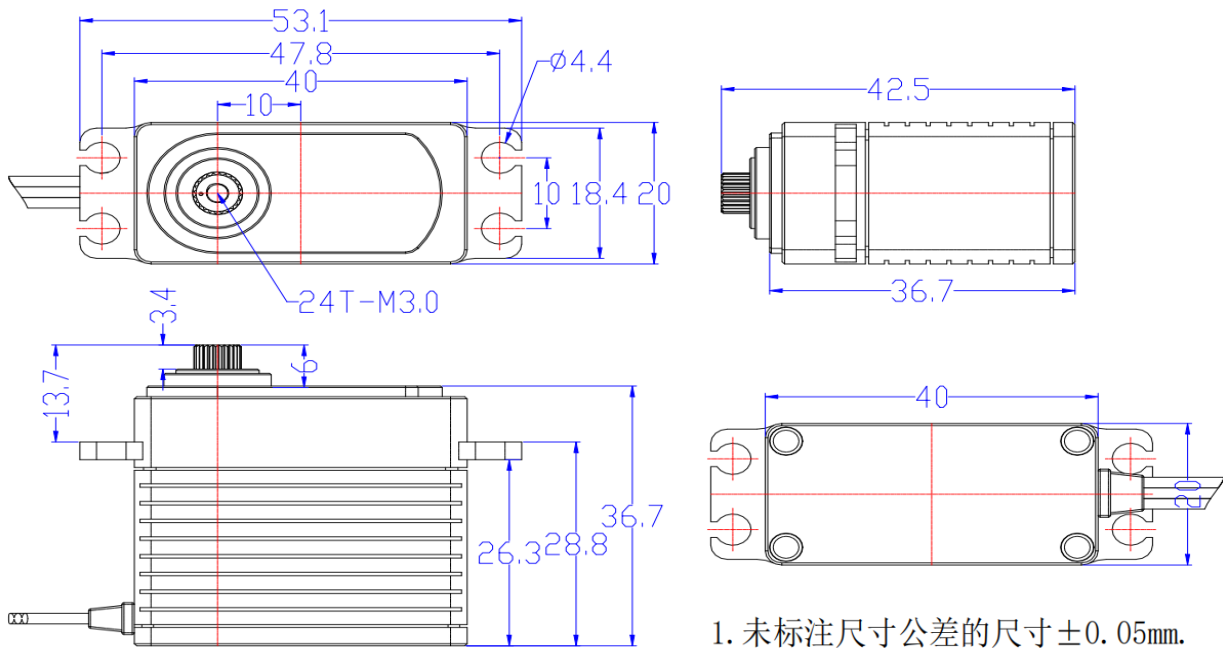



深圳飞特模型有限公司
SHENZHEN FEETECH RC MODEL CO., LTD.

版本EDITION:
A/0

型号/MODEL:
FT935BL-C001

产品规格书
PRODUCT SPECIFICATION

日期/Date:
2023-08-10

页 码 Page: 6/7

10 配件 Accessories

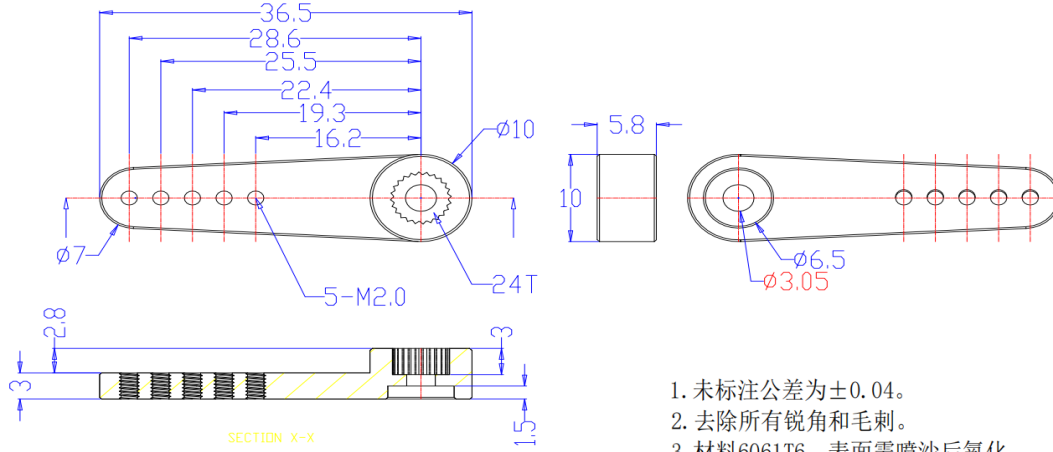

1. 未标注公差为±0.04。
2. 去除所有锐角和毛刺。
3. 材料6061T6，表面需喷沙后氧化

11. 运动特性图 Performance

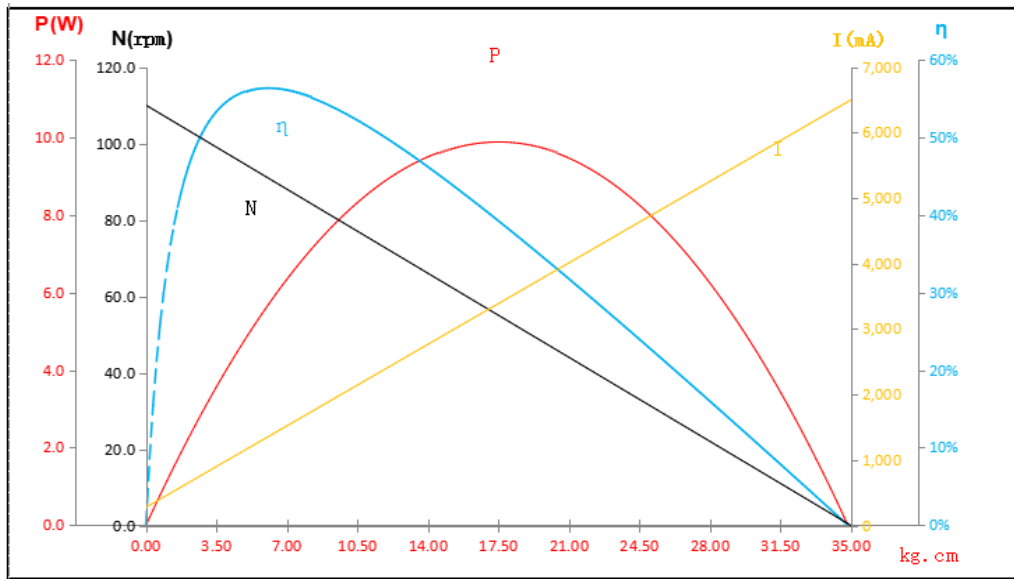

深圳飞特模型有限公司
SHENZHEN FEETECH RC MODEL CO., LTD.

版本EDITION:
A/0

型号/MODEL:
FT935BL-C001

产品规格书
PRODUCT SPECIFICATION

日期/Date:
2023-08-10

页 码 Page: 7/7

12 接口定义 Interface Definition

控制信号参数 (Control signal parameter)

信号周期 Signal Period	20ms	
脉冲宽度 Pulse Width	500us-2500us	
信号高电平电压 Signal high Voltage	2V-5V	
信号低电平电压 Signal Low Voltage	0.0V-0.45V	

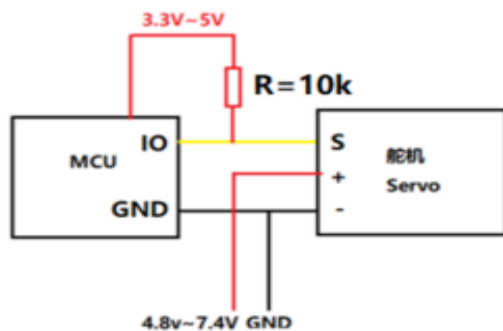

13 包装出货简图 The Packaging Detail



