



1.54 inch E-paper Display Series

Product Specifications



Customer	Standard
Description	1.54" E-PAPER DISPLAY
Model Name	GDEY0154D67
Date	2024/04/17
Revision	1.2

	Design Engineering		
	Approval	Check	Design
			

Zhongnan Building, No.18, Zhonghua West ST,Ganjingzi DST,Dalian,CHINA

Tel: +86-411-84619565

Email: info@good-display.com

Website: www.good-display.com

REVISION HISTORY

Rev	Date	Item	Page	Remark
1.0	NOV.23.2020	New Creation	ALL	
1.1	DEC.14.2023	Note 5-4	9	From Low to High
1.2	Apr.17.2024	Items 11 ~ 15	30~35	Update Reliability test, Inspection method and condition

GOODDISPLAY

CONTENTS

1. Over View-----	5
2. Features-----	5
3. Mechanical Specifications-----	5
4. Mechanical Drawing of EPD module-----	6
5. Input /Output Pin Assignment-----	7
6. Command Table -----	9
7. Electrical Characteristics-----	21
8. Optical Specifications -----	27
9. Typical Application Circuit-----	28
10. Matched Development Kit-----	29
11. Reliability test-----	30
12. Typical Operating Sequence-----	31
13. Inspection method and condition-----	32
14. Handling, Safety and Environment Requirements -----	36
15. Packaging-----	37
16. Precautions-----	38

1. Over View

GDEY0154D67 is a TFT active matrix electrophoretic display, with interface and a reference system design. The 1.54" active area contains 200×200 pixels, and has 1-bit black/white full display capabilities. An integrated circuit contains gate buffer, source buffer, interface, timing control logic, oscillator, DC-DC, SRAM, LUT, VCOM and border are supplied with each panel.

2.Features

- High contrast
- High reflectance
- Ultra wide viewing angle
- Ultra low power consumption
- Pure reflective mode
- Bi-stable
- Commercial temperature range
- Landscape, portrait mode
- Antiglare hard-coated front-surface
- Low current sleep mode
- On chip display RAM
- Serial peripheral interface available
- On-chip oscillator
- On-chip booster and regulator control for generating VCOM, Gate and source driving voltage
- I2C Signal Master Interface to read external temperature sensor
- Available in COG package IC thickness 300um

3.Mechanical Specifications

Parameter	Specifications	Unit	Remark
Screen Size	1.54	Inch	
Display Resolution	200(H)×200(V)	Pixel	Dpi:184
Active Area	27.0(H)×27.0(V)	mm	
Pixel Pitch	0.14×0.14	mm	
Pixel Configuration	Square		
Outline Dimension	31.80(H)×37.32(V) ×1.0(D)	mm	
Weight	2.18±0.5	g	

4. Mechanical Drawing of EPD module

<i>CUSTOMER'S APPROVED:</i>	<i>DATE:</i>	<i>PAGE:1/1</i>
-----------------------------	--------------	-----------------

NO.	REVISION RECORD	NAME	DATE
3			
2	Modify logo	WJZ	2022/01/13
1	Initial version	WJZ	2021/03/16

The drawing shows a 200*200 inch EPD module with a connector. Key dimensions include: overall width 37.32±0.20, overall height 31.80±0.20, and connector length 6.00±0.50. The connector has 24 pins with a pitch of 0.50mm. The module has a PS (Panel Spacing) of 34.30, FPL (Frame Panel Length) of 32.25, and a border of 28.40. The connector pins are labeled with pin numbers 1 through 24.

DALIAN GOOD DISPLAY CO., LTD	
GDEY0154D67	Unit: mm
Dru	Chk
WJZ	Apr

PIN NO.	Symbol
1	NC
2	GDR
3	RESE
4	VGL
5	VGH
6	TSCL
7	TSDA
8	BS1
9	BUSY
10	RST#
11	D/C#
12	CS#
13	SCL
14	SDA
15	VDDIO
16	VCI
17	VSS
18	VDD
19	NC
20	VSH
21	PREVGH
22	VSL
23	PREVGL
24	VCOM

1	Display mode	EPD_B/W
2	Resolution	1.54" 200*200
3	Operating Voltage:	VCI=3.0V
4	Operating Temp:	0°C~50°C
5	Storage Temp:	-25°C~70°C
6	Unspecified tolerance:	±0.2
7	LCD controller/driver:	SSD1681
8	Customer No.:	
9	Dimensions with mark "*" are important	
10	RoHS compliant	

5. Input /Output Pin Assignment

No.	Name	I/O	Description	Remark
1	NC		Do not connect with other NC pins	Keep Open
2	GDR	O	N-Channel MOSFET Gate Drive Control	
3	RESE	I	Current Sense Input for the Control Loop	
4	NC	NC	Do not connect with other NC pins	Keep Open
5	VSH2	C	Positive Source driving voltage(Red)	
6	TSCL	O	I ² C Interface to digital temperature sensor Clock pin	
7	TSDA	I/O	I ² C Interface to digital temperature sensor Data pin	
8	BS1	I	Bus Interface selection pin	Note 5-5
9	BUSY	O	Busy state output pin	Note 5-4
10	RES#	I	Reset signal input. Active Low.	Note 5-3
11	D/C#	I	Data /Command control pin	Note 5-2
12	CS#	I	Chip select input pin	Note 5-1
13	SCL	I	Serial Clock pin (SPI)	
14	SDA	I	Serial Data pin (SPI)	
15	VDDIO	P	Power Supply for interface logic pins It should be connected with VCI	
16	VCI	P	Power Supply for the chip	
17	VSS	P	Ground	
18	VDD	C	Core logic power pin VDD can be regulated internally from VCI. A capacitor should be connected between VDD and VSS	
19	VPP	P	FOR TEST	
20	VSH1	C	Positive Source driving voltage	
21	VGH	C	Power Supply pin for Positive Gate driving voltage and VSH1	
22	VSL	C	Negative Source driving voltage	
23	VGL	C	Power Supply pin for Negative Gate driving voltage VCOM and VSL	
24	VCOM	C	VCOM driving voltage	

Note 5-1: This pin (CS#) is the chip select input connecting to the MCU. The chip is enabled for MCU communication only when CS# is pulled Low.

Note 5-2: This pin (D/C#) is Data/Command control pin connecting to the MCU. When the pin

is pulled High, the data will be interpreted as data. When the pin is pulled Low, the data will be interpreted as command.

Note 5-3: This pin (RES#) is reset signal input. The Reset is active low.

Note 5-4: This pin (BUSY) is Busy state output pin. When Busy is High, the operation of chip should not be interrupted and any commands should not be issued to the module. The driver IC will put Busy pin High when the driver IC is working such as:

Outputting display waveform; or

Communicating with digital temperature sensor

Note 5-5: This pin (BS1) is for 3-line SPI or 4-line SPI selection. When it is "Low", 4-line SPI is selected. When it is "High", 3-line SPI (9 bits SPI) is selected. Please refer to below Table.

BS1 State	MCU Interface
L	4-lines serial peripheral interface(SPI) - 8 bits SPI
H	3- lines serial peripheral interface(SPI) - 9 bits SPI

6. Command Table

Command Table											Command	Description																																																								
R/W#	D/C#	Hex	D7	D6	D5	D4	D3	D2	D1	D0																																																										
0	0	01	0	0	0	0	0	0	0	1	Driver Output control	Gate setting A[8:0]= C7h [POR], 200 MUX MUX Gate lines setting as (A[8:0] + 1). B[2:0] = 000 [POR]. Gate scanning sequence and direction B[2]: GD Selects the 1st output Gate GD=0 [POR], G0 is the 1st gate output channel, gate output sequence is G0,G1, G2, G3, ... GD=1, G1 is the 1st gate output channel, gate output sequence is G1, G0, G3, G2, ... B[1]: SM Change scanning order of gate driver. SM=0 [POR], G0, G1, G2, G3...199 (left and right gate interlaced) SM=1, G0, G2, G4 ...G198, G1, G3, ...G199 B[0]: TB TB = 0 [POR], scan from G0 to G199 TB = 1, scan from G199 to G0.																																																								
0	1		A ₇	A ₆	A ₅	A ₄	A ₃	A ₂	A ₁	A ₀																																																										
0	1		0	0	0	0	0	0	0	A ₈																																																										
0	1		0	0	0	0	0	B ₂	B ₁	B ₀																																																										
0	0	03	0	0	0	0	0	0	1	1	Gate Driving voltage Control	Set Gate driving voltage A[4:0] = 00h [POR] VGH setting from 10V to 20V																																																								
0	1		0	0	0	A ₄	A ₃	A ₂	A ₁	A ₀																																																										
												<table border="1"> <thead> <tr> <th>A[4:0]</th> <th>VGH</th> <th>A[4:0]</th> <th>VGH</th> </tr> </thead> <tbody> <tr> <td>00h</td> <td>20</td> <td>0Dh</td> <td>15</td> </tr> <tr> <td>03h</td> <td>10</td> <td>0Eh</td> <td>15.5</td> </tr> <tr> <td>04h</td> <td>10.5</td> <td>0Fh</td> <td>16</td> </tr> <tr> <td>05h</td> <td>11</td> <td>10h</td> <td>16.5</td> </tr> <tr> <td>06h</td> <td>11.5</td> <td>11h</td> <td>17</td> </tr> <tr> <td>07h</td> <td>12</td> <td>12h</td> <td>17.5</td> </tr> <tr> <td>08h</td> <td>12.5</td> <td>13h</td> <td>18</td> </tr> <tr> <td>07h</td> <td>12</td> <td>14h</td> <td>18.5</td> </tr> <tr> <td>08h</td> <td>12.5</td> <td>15h</td> <td>19</td> </tr> <tr> <td>09h</td> <td>13</td> <td>16h</td> <td>19.5</td> </tr> <tr> <td>0Ah</td> <td>13.5</td> <td>17h</td> <td>20</td> </tr> <tr> <td>0Bh</td> <td>14</td> <td>Other</td> <td>NA</td> </tr> <tr> <td>0Ch</td> <td>14.5</td> <td></td> <td></td> </tr> </tbody> </table>	A[4:0]	VGH	A[4:0]	VGH	00h	20	0Dh	15	03h	10	0Eh	15.5	04h	10.5	0Fh	16	05h	11	10h	16.5	06h	11.5	11h	17	07h	12	12h	17.5	08h	12.5	13h	18	07h	12	14h	18.5	08h	12.5	15h	19	09h	13	16h	19.5	0Ah	13.5	17h	20	0Bh	14	Other	NA	0Ch	14.5		
A[4:0]	VGH	A[4:0]	VGH																																																																	
00h	20	0Dh	15																																																																	
03h	10	0Eh	15.5																																																																	
04h	10.5	0Fh	16																																																																	
05h	11	10h	16.5																																																																	
06h	11.5	11h	17																																																																	
07h	12	12h	17.5																																																																	
08h	12.5	13h	18																																																																	
07h	12	14h	18.5																																																																	
08h	12.5	15h	19																																																																	
09h	13	16h	19.5																																																																	
0Ah	13.5	17h	20																																																																	
0Bh	14	Other	NA																																																																	
0Ch	14.5																																																																			

Command Table

R/W#	D/C#	Hex	D7	D6	D5	D4	D3	D2	D1	D0	Command	Description																																																																																																																																																																																																																																																																																																						
0	0	04	0	0	0	0	0	1	0	0	Source Driving voltage Control	Set Source driving voltage A[7:0] = 41h [POR], VSH1 at 15V B[7:0] = A8h [POR], VSH2 at 5V. C[7:0] = 32h [POR], VSL at -15V Remark: VSH1>=VSH2																																																																																																																																																																																																																																																																																																						
0	1		A7	A6	A5	A4	A3	A2	A1	A0																																																																																																																																																																																																																																																																																																								
0	1		B7	B6	B5	B4	B3	B2	B1	B0																																																																																																																																																																																																																																																																																																								
0	1		C7	C6	C5	C4	C3	C2	C1	C0																																																																																																																																																																																																																																																																																																								
A[7]/B[7] = 1, VSH1/VSH2 voltage setting from 2.4V to 8.8V			A/B[7:0]				VSH1/VSH2																																																																																																																																																																																																																																																																																																											
A[7]/B[7] = 0, VSH1/VSH2 voltage setting from 9V to 17V			A/B[7:0]				VSH1/VSH2																																																																																																																																																																																																																																																																																																											
C[7] = 0, VSL setting from -5V to -17V			C[7:0]		VSL																																																																																																																																																																																																																																																																																																													
			<table border="1"> <thead> <tr> <th>A/B[7:0]</th> <th>VSH1/VSH2</th> <th>A/B[7:0]</th> <th>VSH1/VSH2</th> </tr> </thead> <tbody> <tr><td>8Eh</td><td>2.4</td><td>AFh</td><td>5.7</td></tr> <tr><td>8Fh</td><td>2.5</td><td>B0h</td><td>5.8</td></tr> <tr><td>90h</td><td>2.6</td><td>B1h</td><td>5.9</td></tr> <tr><td>91h</td><td>2.7</td><td>B2h</td><td>6</td></tr> <tr><td>92h</td><td>2.8</td><td>B3h</td><td>6.1</td></tr> <tr><td>93h</td><td>2.9</td><td>B4h</td><td>6.2</td></tr> <tr><td>94h</td><td>3</td><td>B5h</td><td>6.3</td></tr> <tr><td>95h</td><td>3.1</td><td>B6h</td><td>6.4</td></tr> <tr><td>96h</td><td>3.2</td><td>B7h</td><td>6.5</td></tr> <tr><td>97h</td><td>3.3</td><td>B8h</td><td>6.6</td></tr> <tr><td>98h</td><td>3.4</td><td>B9h</td><td>6.7</td></tr> <tr><td>99h</td><td>3.5</td><td>BAh</td><td>6.8</td></tr> <tr><td>9Ah</td><td>3.6</td><td>BBh</td><td>6.9</td></tr> <tr><td>9Bh</td><td>3.7</td><td>BCh</td><td>7</td></tr> <tr><td>9Ch</td><td>3.8</td><td>BDh</td><td>7.1</td></tr> <tr><td>9Dh</td><td>3.9</td><td>BEh</td><td>7.2</td></tr> <tr><td>9Eh</td><td>4</td><td>BFh</td><td>7.3</td></tr> <tr><td>9Fh</td><td>4.1</td><td>C0h</td><td>7.4</td></tr> <tr><td>A0h</td><td>4.2</td><td>C1h</td><td>7.5</td></tr> <tr><td>A1h</td><td>4.3</td><td>C2h</td><td>7.6</td></tr> <tr><td>A2h</td><td>4.4</td><td>C3h</td><td>7.7</td></tr> <tr><td>A3h</td><td>4.5</td><td>C4h</td><td>7.8</td></tr> <tr><td>A4h</td><td>4.6</td><td>C5h</td><td>7.9</td></tr> <tr><td>A5h</td><td>4.7</td><td>C6h</td><td>8</td></tr> <tr><td>A6h</td><td>4.8</td><td>C7h</td><td>8.1</td></tr> <tr><td>A7h</td><td>4.9</td><td>C8h</td><td>8.2</td></tr> <tr><td>A8h</td><td>5</td><td>C9h</td><td>8.3</td></tr> <tr><td>A9h</td><td>5.1</td><td>CAh</td><td>8.4</td></tr> <tr><td>AAh</td><td>5.2</td><td>CBh</td><td>8.5</td></tr> <tr><td>ABh</td><td>5.3</td><td>CCh</td><td>8.6</td></tr> <tr><td>ACh</td><td>5.4</td><td>CDh</td><td>8.7</td></tr> <tr><td>ADh</td><td>5.5</td><td>CEh</td><td>8.8</td></tr> <tr><td>A Eh</td><td>5.6</td><td>Other</td><td>NA</td></tr> </tbody> </table>				A/B[7:0]	VSH1/VSH2	A/B[7:0]	VSH1/VSH2	8Eh	2.4	AFh	5.7	8Fh	2.5	B0h	5.8	90h	2.6	B1h	5.9	91h	2.7	B2h	6	92h	2.8	B3h	6.1	93h	2.9	B4h	6.2	94h	3	B5h	6.3	95h	3.1	B6h	6.4	96h	3.2	B7h	6.5	97h	3.3	B8h	6.6	98h	3.4	B9h	6.7	99h	3.5	BAh	6.8	9Ah	3.6	BBh	6.9	9Bh	3.7	BCh	7	9Ch	3.8	BDh	7.1	9Dh	3.9	BEh	7.2	9Eh	4	BFh	7.3	9Fh	4.1	C0h	7.4	A0h	4.2	C1h	7.5	A1h	4.3	C2h	7.6	A2h	4.4	C3h	7.7	A3h	4.5	C4h	7.8	A4h	4.6	C5h	7.9	A5h	4.7	C6h	8	A6h	4.8	C7h	8.1	A7h	4.9	C8h	8.2	A8h	5	C9h	8.3	A9h	5.1	CAh	8.4	AAh	5.2	CBh	8.5	ABh	5.3	CCh	8.6	ACh	5.4	CDh	8.7	ADh	5.5	CEh	8.8	A Eh	5.6	Other	NA	<table border="1"> <thead> <tr> <th>A/B[7:0]</th> <th>VSH1/VSH2</th> <th>A/B[7:0]</th> <th>VSH1/VSH2</th> </tr> </thead> <tbody> <tr><td>23h</td><td>9</td><td>3Ch</td><td>14</td></tr> <tr><td>24h</td><td>9.2</td><td>3Dh</td><td>14.2</td></tr> <tr><td>25h</td><td>9.4</td><td>3Eh</td><td>14.4</td></tr> <tr><td>26h</td><td>9.6</td><td>3Fh</td><td>14.6</td></tr> <tr><td>27h</td><td>9.8</td><td>40h</td><td>14.8</td></tr> <tr><td>28h</td><td>10</td><td>41h</td><td>15</td></tr> <tr><td>29h</td><td>10.2</td><td>42h</td><td>15.2</td></tr> <tr><td>2Ah</td><td>10.4</td><td>43h</td><td>15.4</td></tr> <tr><td>2Bh</td><td>10.6</td><td>44h</td><td>15.6</td></tr> <tr><td>2Ch</td><td>10.8</td><td>45h</td><td>15.8</td></tr> <tr><td>2Dh</td><td>11</td><td>46h</td><td>16</td></tr> <tr><td>2Eh</td><td>11.2</td><td>47h</td><td>16.2</td></tr> <tr><td>2Fh</td><td>11.4</td><td>48h</td><td>16.4</td></tr> <tr><td>30h</td><td>11.6</td><td>49h</td><td>16.6</td></tr> <tr><td>31h</td><td>11.8</td><td>4Ah</td><td>16.8</td></tr> <tr><td>32h</td><td>12</td><td>4Bh</td><td>17</td></tr> <tr><td>33h</td><td>12.2</td><td>Other</td><td>NA</td></tr> <tr><td>34h</td><td>12.4</td><td></td><td></td></tr> <tr><td>35h</td><td>12.6</td><td></td><td></td></tr> <tr><td>36h</td><td>12.8</td><td></td><td></td></tr> <tr><td>37h</td><td>13</td><td></td><td></td></tr> <tr><td>38h</td><td>13.2</td><td></td><td></td></tr> <tr><td>39h</td><td>13.4</td><td></td><td></td></tr> <tr><td>3Ah</td><td>13.6</td><td></td><td></td></tr> <tr><td>3Bh</td><td>13.8</td><td></td><td></td></tr> </tbody> </table>				A/B[7:0]	VSH1/VSH2	A/B[7:0]	VSH1/VSH2	23h	9	3Ch	14	24h	9.2	3Dh	14.2	25h	9.4	3Eh	14.4	26h	9.6	3Fh	14.6	27h	9.8	40h	14.8	28h	10	41h	15	29h	10.2	42h	15.2	2Ah	10.4	43h	15.4	2Bh	10.6	44h	15.6	2Ch	10.8	45h	15.8	2Dh	11	46h	16	2Eh	11.2	47h	16.2	2Fh	11.4	48h	16.4	30h	11.6	49h	16.6	31h	11.8	4Ah	16.8	32h	12	4Bh	17	33h	12.2	Other	NA	34h	12.4			35h	12.6			36h	12.8			37h	13			38h	13.2			39h	13.4			3Ah	13.6			3Bh	13.8			<table border="1"> <thead> <tr> <th>C[7:0]</th> <th>VSL</th> </tr> </thead> <tbody> <tr><td>0Ah</td><td>-5</td></tr> <tr><td>0Ch</td><td>-5.5</td></tr> <tr><td>0Eh</td><td>-6</td></tr> <tr><td>10h</td><td>-6.5</td></tr> <tr><td>12h</td><td>-7</td></tr> <tr><td>14h</td><td>-7.5</td></tr> <tr><td>16h</td><td>-8</td></tr> <tr><td>18h</td><td>-8.5</td></tr> <tr><td>1Ah</td><td>-9</td></tr> <tr><td>1Ch</td><td>-9.5</td></tr> <tr><td>1Eh</td><td>-10</td></tr> <tr><td>20h</td><td>-10.5</td></tr> <tr><td>22h</td><td>-11</td></tr> <tr><td>24h</td><td>-11.5</td></tr> <tr><td>26h</td><td>-12</td></tr> <tr><td>28h</td><td>-12.5</td></tr> <tr><td>2Ah</td><td>-13</td></tr> <tr><td>2Ch</td><td>-13.5</td></tr> <tr><td>2Eh</td><td>-14</td></tr> <tr><td>30h</td><td>-14.5</td></tr> <tr><td>32h</td><td>-15</td></tr> <tr><td>34h</td><td>-15.5</td></tr> <tr><td>36h</td><td>-16</td></tr> <tr><td>38h</td><td>-16.5</td></tr> <tr><td>3Ah</td><td>-17</td></tr> <tr><td>Other</td><td>NA</td></tr> </tbody> </table>		C[7:0]	VSL	0Ah	-5	0Ch	-5.5	0Eh	-6	10h	-6.5	12h	-7	14h	-7.5	16h	-8	18h	-8.5	1Ah	-9	1Ch	-9.5	1Eh	-10	20h	-10.5	22h	-11	24h	-11.5	26h	-12	28h	-12.5	2Ah	-13	2Ch	-13.5	2Eh	-14	30h	-14.5	32h	-15	34h	-15.5	36h	-16	38h	-16.5	3Ah	-17	Other	NA
A/B[7:0]	VSH1/VSH2	A/B[7:0]	VSH1/VSH2																																																																																																																																																																																																																																																																																																															
8Eh	2.4	AFh	5.7																																																																																																																																																																																																																																																																																																															
8Fh	2.5	B0h	5.8																																																																																																																																																																																																																																																																																																															
90h	2.6	B1h	5.9																																																																																																																																																																																																																																																																																																															
91h	2.7	B2h	6																																																																																																																																																																																																																																																																																																															
92h	2.8	B3h	6.1																																																																																																																																																																																																																																																																																																															
93h	2.9	B4h	6.2																																																																																																																																																																																																																																																																																																															
94h	3	B5h	6.3																																																																																																																																																																																																																																																																																																															
95h	3.1	B6h	6.4																																																																																																																																																																																																																																																																																																															
96h	3.2	B7h	6.5																																																																																																																																																																																																																																																																																																															
97h	3.3	B8h	6.6																																																																																																																																																																																																																																																																																																															
98h	3.4	B9h	6.7																																																																																																																																																																																																																																																																																																															
99h	3.5	BAh	6.8																																																																																																																																																																																																																																																																																																															
9Ah	3.6	BBh	6.9																																																																																																																																																																																																																																																																																																															
9Bh	3.7	BCh	7																																																																																																																																																																																																																																																																																																															
9Ch	3.8	BDh	7.1																																																																																																																																																																																																																																																																																																															
9Dh	3.9	BEh	7.2																																																																																																																																																																																																																																																																																																															
9Eh	4	BFh	7.3																																																																																																																																																																																																																																																																																																															
9Fh	4.1	C0h	7.4																																																																																																																																																																																																																																																																																																															
A0h	4.2	C1h	7.5																																																																																																																																																																																																																																																																																																															
A1h	4.3	C2h	7.6																																																																																																																																																																																																																																																																																																															
A2h	4.4	C3h	7.7																																																																																																																																																																																																																																																																																																															
A3h	4.5	C4h	7.8																																																																																																																																																																																																																																																																																																															
A4h	4.6	C5h	7.9																																																																																																																																																																																																																																																																																																															
A5h	4.7	C6h	8																																																																																																																																																																																																																																																																																																															
A6h	4.8	C7h	8.1																																																																																																																																																																																																																																																																																																															
A7h	4.9	C8h	8.2																																																																																																																																																																																																																																																																																																															
A8h	5	C9h	8.3																																																																																																																																																																																																																																																																																																															
A9h	5.1	CAh	8.4																																																																																																																																																																																																																																																																																																															
AAh	5.2	CBh	8.5																																																																																																																																																																																																																																																																																																															
ABh	5.3	CCh	8.6																																																																																																																																																																																																																																																																																																															
ACh	5.4	CDh	8.7																																																																																																																																																																																																																																																																																																															
ADh	5.5	CEh	8.8																																																																																																																																																																																																																																																																																																															
A Eh	5.6	Other	NA																																																																																																																																																																																																																																																																																																															
A/B[7:0]	VSH1/VSH2	A/B[7:0]	VSH1/VSH2																																																																																																																																																																																																																																																																																																															
23h	9	3Ch	14																																																																																																																																																																																																																																																																																																															
24h	9.2	3Dh	14.2																																																																																																																																																																																																																																																																																																															
25h	9.4	3Eh	14.4																																																																																																																																																																																																																																																																																																															
26h	9.6	3Fh	14.6																																																																																																																																																																																																																																																																																																															
27h	9.8	40h	14.8																																																																																																																																																																																																																																																																																																															
28h	10	41h	15																																																																																																																																																																																																																																																																																																															
29h	10.2	42h	15.2																																																																																																																																																																																																																																																																																																															
2Ah	10.4	43h	15.4																																																																																																																																																																																																																																																																																																															
2Bh	10.6	44h	15.6																																																																																																																																																																																																																																																																																																															
2Ch	10.8	45h	15.8																																																																																																																																																																																																																																																																																																															
2Dh	11	46h	16																																																																																																																																																																																																																																																																																																															
2Eh	11.2	47h	16.2																																																																																																																																																																																																																																																																																																															
2Fh	11.4	48h	16.4																																																																																																																																																																																																																																																																																																															
30h	11.6	49h	16.6																																																																																																																																																																																																																																																																																																															
31h	11.8	4Ah	16.8																																																																																																																																																																																																																																																																																																															
32h	12	4Bh	17																																																																																																																																																																																																																																																																																																															
33h	12.2	Other	NA																																																																																																																																																																																																																																																																																																															
34h	12.4																																																																																																																																																																																																																																																																																																																	
35h	12.6																																																																																																																																																																																																																																																																																																																	
36h	12.8																																																																																																																																																																																																																																																																																																																	
37h	13																																																																																																																																																																																																																																																																																																																	
38h	13.2																																																																																																																																																																																																																																																																																																																	
39h	13.4																																																																																																																																																																																																																																																																																																																	
3Ah	13.6																																																																																																																																																																																																																																																																																																																	
3Bh	13.8																																																																																																																																																																																																																																																																																																																	
C[7:0]	VSL																																																																																																																																																																																																																																																																																																																	
0Ah	-5																																																																																																																																																																																																																																																																																																																	
0Ch	-5.5																																																																																																																																																																																																																																																																																																																	
0Eh	-6																																																																																																																																																																																																																																																																																																																	
10h	-6.5																																																																																																																																																																																																																																																																																																																	
12h	-7																																																																																																																																																																																																																																																																																																																	
14h	-7.5																																																																																																																																																																																																																																																																																																																	
16h	-8																																																																																																																																																																																																																																																																																																																	
18h	-8.5																																																																																																																																																																																																																																																																																																																	
1Ah	-9																																																																																																																																																																																																																																																																																																																	
1Ch	-9.5																																																																																																																																																																																																																																																																																																																	
1Eh	-10																																																																																																																																																																																																																																																																																																																	
20h	-10.5																																																																																																																																																																																																																																																																																																																	
22h	-11																																																																																																																																																																																																																																																																																																																	
24h	-11.5																																																																																																																																																																																																																																																																																																																	
26h	-12																																																																																																																																																																																																																																																																																																																	
28h	-12.5																																																																																																																																																																																																																																																																																																																	
2Ah	-13																																																																																																																																																																																																																																																																																																																	
2Ch	-13.5																																																																																																																																																																																																																																																																																																																	
2Eh	-14																																																																																																																																																																																																																																																																																																																	
30h	-14.5																																																																																																																																																																																																																																																																																																																	
32h	-15																																																																																																																																																																																																																																																																																																																	
34h	-15.5																																																																																																																																																																																																																																																																																																																	
36h	-16																																																																																																																																																																																																																																																																																																																	
38h	-16.5																																																																																																																																																																																																																																																																																																																	
3Ah	-17																																																																																																																																																																																																																																																																																																																	
Other	NA																																																																																																																																																																																																																																																																																																																	
0	0	08	0	0	0	0	1	0	0	0	Initial Code Setting OTP Program	Program Initial Code Setting The command required CLKEN=1. Refer to Register 0x22 for detail. BUSY pad will output high during operation.																																																																																																																																																																																																																																																																																																						
0	0	09	0	0	0	0	1	0	0	1	Write Register for Initial Code Setting	Write Register for Initial Code Setting Selection A[7:0] ~ D[7:0]: Reserved Details refer to Application Notes of Initial Code Setting																																																																																																																																																																																																																																																																																																						
0	1		A7	A6	A5	A4	A3	A2	A1	A0																																																																																																																																																																																																																																																																																																								
0	1		B7	B6	B5	B4	B3	B2	B1	B0																																																																																																																																																																																																																																																																																																								
0	1		C7	C6	C5	C4	C3	C2	C1	C0																																																																																																																																																																																																																																																																																																								
0	1		D7	D6	D5	D4	D3	D2	D1	D0																																																																																																																																																																																																																																																																																																								
0	0	0A	0	0	0	0	1	0	1	0	Read Register for Initial Code Setting	Read Register for Initial Code Setting																																																																																																																																																																																																																																																																																																						

Command Table											Command	Description																																																		
R/W#	D/C#	Hex	D7	D6	D5	D4	D3	D2	D1	D0																																																				
0	0	0C	0	0	0	0	1	1	0	0	Booster Soft start Control	Booster Enable with Phase 1, Phase 2 and Phase 3 for soft start current and duration setting. A[7:0] -> Soft start setting for Phase1 = 8Bh [POR] B[7:0] -> Soft start setting for Phase2 = 9Ch [POR] C[7:0] -> Soft start setting for Phase3 = 96h [POR] D[7:0] -> Duration setting = 0Fh [POR] Bit Description of each byte: A[6:0] / B[6:0] / C[6:0]:																																																		
0	1		1	A ₆	A ₅	A ₄	A ₃	A ₂	A ₁	A ₀																																																				
0	1		1	B ₆	B ₅	B ₄	B ₃	B ₂	B ₁	B ₀																																																				
0	1		1	C ₆	C ₅	C ₄	C ₃	C ₂	C ₁	C ₀																																																				
0	1		0	0	D ₅	D ₄	D ₃	D ₂	D ₁	D ₀																																																				
												<table border="1"> <thead> <tr> <th>Bit[6:4]</th> <th>Driving Strength Selection</th> </tr> </thead> <tbody> <tr><td>000</td><td>1(Weakest)</td></tr> <tr><td>001</td><td>2</td></tr> <tr><td>010</td><td>3</td></tr> <tr><td>011</td><td>4</td></tr> <tr><td>100</td><td>5</td></tr> <tr><td>101</td><td>6</td></tr> <tr><td>110</td><td>7</td></tr> <tr><td>111</td><td>8(Strongest)</td></tr> </tbody> </table> <table border="1"> <thead> <tr> <th>Bit[3:0]</th> <th>Min Off Time Setting of GDR [Time unit]</th> </tr> </thead> <tbody> <tr><td>0000</td><td>NA</td></tr> <tr><td>~</td><td></td></tr> <tr><td>0011</td><td></td></tr> <tr><td>0100</td><td>2.6</td></tr> <tr><td>0101</td><td>3.2</td></tr> <tr><td>0110</td><td>3.9</td></tr> <tr><td>0111</td><td>4.6</td></tr> <tr><td>1000</td><td>5.4</td></tr> <tr><td>1001</td><td>6.3</td></tr> <tr><td>1010</td><td>7.3</td></tr> <tr><td>1011</td><td>8.4</td></tr> <tr><td>1100</td><td>9.8</td></tr> <tr><td>1101</td><td>11.5</td></tr> <tr><td>1110</td><td>13.8</td></tr> <tr><td>1111</td><td>16.5</td></tr> </tbody> </table> D[5:0]: duration setting of phase D[5:4]: duration setting of phase 3 D[3:2]: duration setting of phase 2 D[1:0]: duration setting of phase 1	Bit[6:4]	Driving Strength Selection	000	1(Weakest)	001	2	010	3	011	4	100	5	101	6	110	7	111	8(Strongest)	Bit[3:0]	Min Off Time Setting of GDR [Time unit]	0000	NA	~		0011		0100	2.6	0101	3.2	0110	3.9	0111	4.6	1000	5.4	1001	6.3	1010	7.3	1011	8.4	1100	9.8	1101	11.5	1110	13.8	1111	16.5
Bit[6:4]	Driving Strength Selection																																																													
000	1(Weakest)																																																													
001	2																																																													
010	3																																																													
011	4																																																													
100	5																																																													
101	6																																																													
110	7																																																													
111	8(Strongest)																																																													
Bit[3:0]	Min Off Time Setting of GDR [Time unit]																																																													
0000	NA																																																													
~																																																														
0011																																																														
0100	2.6																																																													
0101	3.2																																																													
0110	3.9																																																													
0111	4.6																																																													
1000	5.4																																																													
1001	6.3																																																													
1010	7.3																																																													
1011	8.4																																																													
1100	9.8																																																													
1101	11.5																																																													
1110	13.8																																																													
1111	16.5																																																													
												<table border="1"> <thead> <tr> <th>Bit[1:0]</th> <th>Duration of Phase [Approximation]</th> </tr> </thead> <tbody> <tr><td>00</td><td>10ms</td></tr> <tr><td>01</td><td>20ms</td></tr> <tr><td>10</td><td>30ms</td></tr> <tr><td>11</td><td>40ms</td></tr> </tbody> </table>	Bit[1:0]	Duration of Phase [Approximation]	00	10ms	01	20ms	10	30ms	11	40ms																																								
Bit[1:0]	Duration of Phase [Approximation]																																																													
00	10ms																																																													
01	20ms																																																													
10	30ms																																																													
11	40ms																																																													
0	0	10	0	0	0	1	0	0	0	0	Deep Sleep mode	Deep Sleep mode Control:																																																		
0	1		0	0	0	0	0	0	A ₁	A ₀																																																				
												<table border="1"> <thead> <tr> <th>A[1:0]</th> <th>Description</th> </tr> </thead> <tbody> <tr><td>00</td><td>Normal Mode [POR]</td></tr> <tr><td>01</td><td>Enter Deep Sleep Mode 1</td></tr> <tr><td>11</td><td>Enter Deep Sleep Mode 2</td></tr> </tbody> </table> After this command initiated, the chip will enter Deep Sleep Mode, BUSY pad will keep output high. Remark: To Exit Deep Sleep mode, User required to send HWRESET to the driver	A[1:0]	Description	00	Normal Mode [POR]	01	Enter Deep Sleep Mode 1	11	Enter Deep Sleep Mode 2																																										
A[1:0]	Description																																																													
00	Normal Mode [POR]																																																													
01	Enter Deep Sleep Mode 1																																																													
11	Enter Deep Sleep Mode 2																																																													

Command Table																										
R/W#	D/C#	Hex	D7	D6	D5	D4	D3	D2	D1	D0	Command	Description														
0	0	14	0	0	0	1	0	1	0	0	HV Ready Detection	HV ready detection A[7:0] = 00h [POR] The command required CLKEN=1 and ANALOGEN=1. Refer to Register 0x22 for detail. After this command initiated, HV Ready detection starts. BUSY pad will output high during detection. The detection result can be read from the Status Bit Read (Command 0x2F).														
0	1		0	A ₆	A ₅	A ₄	0	A ₂	A ₁	A ₀			A[6:4]=n for cool down duration: 10ms x (n+1) A[2:0]=m for number of Cool Down Loop to detect. The max HV ready duration is 10ms x (n+1) x (m) HV ready detection will be trigger after each cool down time. The detection will be completed when HV is ready. For 1 shot HV ready detection, A[7:0] can be set as 00h.													
0	0	15	0	0	0	1	0	1	0	1	VCI Detection	VCI Detection A[2:0] = 100 [POR] , Detect level at 2.3V A[2:0] : VCI level Detect <table border="1" style="margin-left: 20px;"> <thead> <tr> <th>A[2:0]</th> <th>VCI level</th> </tr> </thead> <tbody> <tr> <td>011</td> <td>2.2V</td> </tr> <tr> <td>100</td> <td>2.3V</td> </tr> <tr> <td>101</td> <td>2.4V</td> </tr> <tr> <td>110</td> <td>2.5V</td> </tr> <tr> <td>111</td> <td>2.6V</td> </tr> <tr> <td>Other</td> <td>NA</td> </tr> </tbody> </table>	A[2:0]	VCI level	011	2.2V	100	2.3V	101	2.4V	110	2.5V	111	2.6V	Other	NA
A[2:0]	VCI level																									
011	2.2V																									
100	2.3V																									
101	2.4V																									
110	2.5V																									
111	2.6V																									
Other	NA																									
0	1		0	0	0	0	0	A ₂	A ₁	A ₀	The command required CLKEN=1 and ANALOGEN=1 Refer to Register 0x22 for detail. After this command initiated, VCI detection starts. BUSY pad will output high during detection. The detection result can be read from the Status Bit Read (Command 0x2F).															
0	0	18	0	0	0	1	1	0	0	0	Temperature Sensor Control	Temperature Sensor Selection A[7:0] = 48h [POR], external temperature sensor A[7:0] = 80h Internal temperature sensor														
0	1		A ₇	A ₆	A ₅	A ₄	A ₃	A ₂	A ₁	A ₀																
0	0	1A	0	0	0	1	1	0	1	0	Temperature Sensor Control (Write to temperature register)	Write to temperature register. A[11:0] = 7FFh [POR]														
0	1		A ₁₁	A ₁₀	A ₉	A ₈	A ₇	A ₆	A ₅	A ₄																
0	1		A ₃	A ₂	A ₁	A ₀	0	0	0	0																
0	0	1B	0	0	0	1	1	0	1	1	Temperature Sensor Control (Read from temperature register)	Read from temperature register.														
1	1		A ₁₁	A ₁₀	A ₉	A ₈	A ₇	A ₆	A ₅	A ₄																
1	1		A ₃	A ₂	A ₁	A ₀	0	0	0	0																
0	0	12	0	0	0	1	0	0	1	0	SW RESET	It resets the commands and parameters to their S/W Reset default values except R10h-Deep Sleep Mode During operation, BUSY pad will output high. Note: RAM are unaffected by this command.														

Command Table																								
R/W#	D/C#	Hex	D7	D6	D5	D4	D3	D2	D1	D0	Command	Description												
0	0	1C	0	0	0	1	1	1	0	0	Temperature Sensor Control (Write Command to External temperature sensor)	Write Command to External temperature sensor. A[7:0] = 00h [POR], B[7:0] = 00h [POR], C[7:0] = 00h [POR], A[7:6] <table border="1"> <tr> <td>A[7:6]</td> <td>Select no of byte to be sent</td> </tr> <tr> <td>00</td> <td>Address + pointer</td> </tr> <tr> <td>01</td> <td>Address + pointer + 1st parameter</td> </tr> <tr> <td>10</td> <td>Address + pointer + 1st parameter + 2nd pointer</td> </tr> <tr> <td>11</td> <td>Address</td> </tr> </table> A[5:0] – Pointer Setting B[7:0] – 1 st parameter C[7:0] – 2 nd parameter The command required CLKEN=1. Refer to Register 0x22 for detail. After this command initiated, Write Command to external temperature sensor starts. BUSY pad will output high during operation.	A[7:6]	Select no of byte to be sent	00	Address + pointer	01	Address + pointer + 1st parameter	10	Address + pointer + 1st parameter + 2nd pointer	11	Address		
A[7:6]	Select no of byte to be sent																							
00	Address + pointer																							
01	Address + pointer + 1st parameter																							
10	Address + pointer + 1st parameter + 2nd pointer																							
11	Address																							
0	1		A ₇	A ₆	A ₅	A ₄	A ₃	A ₂	A ₁	A ₀														
0	1		B ₇	B ₆	B ₅	B ₄	B ₃	B ₂	B ₁	B ₀														
0	1		C ₇	C ₆	C ₅	C ₄	C ₃	C ₂	C ₁	C ₀														
0	0	20	0	0	1	0	0	0	0	0	Master Activation	Activate Display Update Sequence The Display Update Sequence Option is located at R22h. BUSY pad will output high during operation. User should not interrupt this operation to avoid corruption of panel images.												
0	0	21	0	0	1	0	0	0	0	1	Display Update Control	RAM content option for Display Update A[7:0] = 00h [POR] B[7:0] = 00h [POR] A[7:4] Red RAM option <table border="1"> <tr> <td>0000</td> <td>Normal</td> </tr> <tr> <td>0100</td> <td>Bypass RAM content as 0</td> </tr> <tr> <td>1000</td> <td>Inverse RAM content</td> </tr> </table> A[3:0] BW RAM option <table border="1"> <tr> <td>0000</td> <td>Normal</td> </tr> <tr> <td>0100</td> <td>Bypass RAM content as 0</td> </tr> <tr> <td>1000</td> <td>Inverse RAM content</td> </tr> </table>	0000	Normal	0100	Bypass RAM content as 0	1000	Inverse RAM content	0000	Normal	0100	Bypass RAM content as 0	1000	Inverse RAM content
0000	Normal																							
0100	Bypass RAM content as 0																							
1000	Inverse RAM content																							
0000	Normal																							
0100	Bypass RAM content as 0																							
1000	Inverse RAM content																							
0	1		A ₇	A ₆	A ₅	A ₄	A ₃	A ₂	A ₁	A ₀														
0	0	11	0	0	0	1	0	0	0	1	Data Entry mode setting	Define data entry sequence A[2:0] = 011 [POR] A [1:0] = ID[1:0] Address automatic increment / decrement setting The setting of incrementing or decrementing of the address counter can be made independently in each upper and lower bit of the address. 00 –Y decrement, X decrement, 01 –Y decrement, X increment, 10 –Y increment, X decrement, 11 –Y increment, X increment [POR] A[2] = AM Set the direction in which the address counter is updated automatically after data are written to the RAM. AM= 0, the address counter is updated in the X direction. [POR] AM = 1, the address counter is updated in the Y direction.												
0	1		0	0	0	0	0	A ₂	A ₁	A ₀														

Command Table											Command	Description																									
R/W#	D/C#	Hex	D7	D6	D5	D4	D3	D2	D1	D0																											
0	0	22	0	0	1	0	0	0	1	0	Display Update Control 2	Display Update Sequence Option: Enable the stage for Master Activation A[7:0]= FFh (POR)																									
0	1		A ₇	A ₆	A ₅	A ₄	A ₃	A ₂	A ₁	A ₀			<table border="1"> <thead> <tr> <th>Operating sequence</th> <th>Parameter (in Hex)</th> </tr> </thead> <tbody> <tr> <td>Enable clock signal</td> <td>80</td> </tr> <tr> <td>Disable clock signal</td> <td>01</td> </tr> <tr> <td>Enable clock signal → Enable Analog</td> <td>C0</td> </tr> <tr> <td>Disable Analog → Disable clock signal</td> <td>03</td> </tr> <tr> <td>Enable clock signal → Load LUT with DISPLAY Mode 1 → Disable clock signal</td> <td>91</td> </tr> <tr> <td>Enable clock signal → Load LUT with DISPLAY Mode 2 → Disable clock signal</td> <td>99</td> </tr> <tr> <td>Enable clock signal → Load temperature value → Load LUT with DISPLAY Mode 1 → Disable clock signal</td> <td>B1</td> </tr> <tr> <td>Enable clock signal → Load temperature value → Load LUT with DISPLAY Mode 2 → Disable clock signal</td> <td>B9</td> </tr> <tr> <td>Enable clock signal → Enable Analog → Display with DISPLAY Mode 1 → Disable Analog → Disable OSC</td> <td>C7</td> </tr> <tr> <td>Enable clock signal → Enable Analog → Display with DISPLAY Mode 2 → Disable Analog → Disable OSC</td> <td>CF</td> </tr> <tr> <td>Enable clock signal → Enable Analog → Load temperature value → DISPLAY with DISPLAY Mode 1 → Disable Analog → Disable OSC</td> <td>F7</td> </tr> <tr> <td>Enable clock signal → Enable Analog → Load temperature value → DISPLAY with DISPLAY Mode 2 → Disable Analog → Disable OSC</td> <td>FF</td> </tr> </tbody> </table>	Operating sequence	Parameter (in Hex)	Enable clock signal	80	Disable clock signal	01	Enable clock signal → Enable Analog	C0	Disable Analog → Disable clock signal	03	Enable clock signal → Load LUT with DISPLAY Mode 1 → Disable clock signal	91	Enable clock signal → Load LUT with DISPLAY Mode 2 → Disable clock signal	99	Enable clock signal → Load temperature value → Load LUT with DISPLAY Mode 1 → Disable clock signal	B1	Enable clock signal → Load temperature value → Load LUT with DISPLAY Mode 2 → Disable clock signal	B9	Enable clock signal → Enable Analog → Display with DISPLAY Mode 1 → Disable Analog → Disable OSC	C7	Enable clock signal → Enable Analog → Display with DISPLAY Mode 2 → Disable Analog → Disable OSC	CF	Enable clock signal → Enable Analog → Load temperature value → DISPLAY with DISPLAY Mode 1 → Disable Analog → Disable OSC	F7
Operating sequence	Parameter (in Hex)																																				
Enable clock signal	80																																				
Disable clock signal	01																																				
Enable clock signal → Enable Analog	C0																																				
Disable Analog → Disable clock signal	03																																				
Enable clock signal → Load LUT with DISPLAY Mode 1 → Disable clock signal	91																																				
Enable clock signal → Load LUT with DISPLAY Mode 2 → Disable clock signal	99																																				
Enable clock signal → Load temperature value → Load LUT with DISPLAY Mode 1 → Disable clock signal	B1																																				
Enable clock signal → Load temperature value → Load LUT with DISPLAY Mode 2 → Disable clock signal	B9																																				
Enable clock signal → Enable Analog → Display with DISPLAY Mode 1 → Disable Analog → Disable OSC	C7																																				
Enable clock signal → Enable Analog → Display with DISPLAY Mode 2 → Disable Analog → Disable OSC	CF																																				
Enable clock signal → Enable Analog → Load temperature value → DISPLAY with DISPLAY Mode 1 → Disable Analog → Disable OSC	F7																																				
Enable clock signal → Enable Analog → Load temperature value → DISPLAY with DISPLAY Mode 2 → Disable Analog → Disable OSC	FF																																				
0	0	24	0	0	1	0	0	1	0	0	Write RAM (Black White) / RAM 0x24	After this command, data entries will be written into the BW RAM until another command is written. Address pointers will advance accordingly For Write pixel: Content of Write RAM(BW) = 1 For Black pixel: Content of Write RAM(BW) = 0																									

Command Table											Command	Description
R/W#	D/C#	Hex	D7	D6	D5	D4	D3	D2	D1	D0		
0	0	26	0	0	1	0	0	1	1	0	Write RAM (RED) / RAM 0x26	After this command, data entries will be written into the RED RAM until another command is written. Address pointers will advance accordingly. For Red pixel: Content of Write RAM(RED) = 1 For non-Red pixel [Black or White]: Content of Write RAM(RED) = 0
0	0	27	0	0	1	0	0	1	1	1	Read RAM	After this command, data read on the MCU bus will fetch data from RAM. According to parameter of Register 41h to select reading RAM0x24/ RAM0x26, until another command is written. Address pointers will advance accordingly. The 1 st byte of data read is dummy data.
0	0	28	0	0	1	0	1	0	0	0	VCOM Sense	Enter VCOM sensing conditions and hold for duration defined in 29h before reading VCOM value. The sensed VCOM voltage is stored in register The command required CLKEN=1 and ANALOGEN=1 Refer to Register 0x22 for detail. BUSY pad will output high during operation.
0	0	29	0	0	1	0	1	0	0	1	VCOM Sense Duration	Stabling time between entering VCOM sensing mode and reading acquired. A[3:0] = 9h, duration = 10s. VCOM sense duration = (A[3:0]+1) sec
0	1		0	1	0	0	A ₃	A ₂	A ₁	A ₀		
0	0	2A	0	0	1	0	1	0	1	0	Program VCOM OTP	Program VCOM register into OTP The command required CLKEN=1. Refer to Register 0x22 for detail. BUSY pad will output high during operation.
0	0	2B	0	0	1	0	1	0	1	1	Write Register for VCOM Control	This command is used to reduce glitch when ACVCOM toggle. Two data bytes D04h and D63h should be set for this command.
0	1		0	0	0	0	0	1	0	0		
0	1		0	1	1	0	0	0	1	1		

Command Table																
R/W#	D/C#	Hex	D7	D6	D5	D4	D3	D2	D1	D0	Command	Description				
0	0	2C	0	0	1	0	1	1	0	0	Write VCOM register	Write VCOM register from MCU interface A[7:0] = 00h [POR]				
0	1		A7	A6	A5	A4	A3	A2	A1	A0						
													A[7:0]	VCOM	A[7:0]	VCOM
													08h	-0.2	44h	-1.7
													0Ch	-0.3	48h	-1.8
													10h	-0.4	4Ch	-1.9
													14h	-0.5	50h	-2
													18h	-0.6	54h	-2.1
													1Ch	-0.7	58h	-2.2
													20h	-0.8	5Ch	-2.3
													24h	-0.9	60h	-2.4
													28h	-1	64h	-2.5
													2Ch	-1.1	68h	-2.6
													30h	-1.2	6Ch	-2.7
													34h	-1.3	70h	-2.8
											38h	-1.4	74h	-2.9		
											3Ch	-1.5	78h	-3		
											40h	-1.6	Other	NA		
0	0	2D	0	0	1	0	1	1	0	1	OTP Register Read for Display Option	Read Register for Display Option: A[7:0]: VCOM OTP Selection (Command 0x37, Byte A) B[7:0]: VCOM Register (Command 0x2C) C[7:0]~G[7:0]: Display Mode (Command 0x37, Byte B to Byte F) [5 bytes] H[7:0]~K[7:0]: Waveform Version (Command 0x37, Byte G to Byte J) [4 bytes]				
1	1		A7	A6	A5	A4	A3	A2	A1	A0						
1	1		B7	B6	B5	B4	B3	B2	B1	B0						
1	1		C7	C6	C5	C4	C3	C2	C1	C0						
1	1		D7	D6	D5	D4	D3	D2	D1	D0						
1	1		E7	E6	E5	E4	E3	E2	E1	E0						
1	1		F7	F6	F5	F4	F3	F2	F1	F0						
1	1		G7	G6	G5	G4	G3	G2	G1	G0						
1	1		H7	H6	H5	H4	H3	H2	H1	H0						
1	1		I7	I6	I5	I4	I3	I2	I1	I0						
1	1		J7	J6	J5	J4	J3	J2	J1	J0						
1	1		K7	K6	K5	K4	K3	K2	K1	K0						
0	0	2E	0	0	1	0	1	1	1	0	User ID Read	Read 10 Byte User ID stored in OTP: A[7:0]~J[7:0]: UserID (R38, Byte A and Byte J) [10 bytes]				
1	1		A7	A6	A5	A4	A3	A2	A1	A0						
1	1		B7	B6	B5	B4	B3	B2	B1	B0						
1	1		C7	C6	C5	C4	C3	C2	C1	C0						
1	1		D7	D6	D5	D4	D3	D2	D1	D0						
1	1		E7	E6	E5	E4	E3	E2	E1	E0						
1	1		F7	F6	F5	F4	F3	F2	F1	F0						
1	1		G7	G6	G5	G4	G3	G2	G1	G0						
1	1		H7	H6	H5	H4	H3	H2	H1	H0						
1	1		I7	I6	I5	I4	I3	I2	I1	I0						
1	1		J7	J6	J5	J4	J3	J2	J1	J0						

Command Table												
R/W#	D/C#	Hex	D7	D6	D5	D4	D3	D2	D1	D0	Command	Description
0	0	2F	0	0	1	0	1	1	1	1	Status Bit Read	Read IC status Bit [POR 0x01] A[5]: HV Ready Detection flag [POR=0] 0: Ready 1: Not Ready A[4]: VCI Detection flag [POR=0] 0: Normal 1: VCI lower than the Detect level A[3]: [POR=0] A[2]: Busy flag [POR=0] 0: Normal 1: BUSY A[1:0]: Chip ID [POR=01] Remark: A[5] and A[4] status are not valid after RESET, they need to be initiated by command 0x14 and command 0x15 respectively.
1	1		0	0	A ₅	A ₄	0	0	A ₁	A ₀		
0	0	30	0	0	1	1	0	0	0	0	Program WS OTP	Program OTP of Waveform Setting The contents should be written into RAM before sending this command. The command required CLKEN=1. Refer to Register 0x22 for detail. BUSY pad will output high during operation.
0	0	31	0	0	1	1	0	0	0	1	Load WS OTP	Load OTP of Waveform Setting The command required CLKEN=1. Refer to Register 0x22 for detail. BUSY pad will output high during operation.
0	0	32	0	0	1	1	0	0	1	0	Write LUT register	Write LUT register from MCU interface [153 bytes], which contains the content of VS[nX-LUTm], TP[nX], RP[n], SR[nXY], and FR[n] Refer to Session 6.7 WAVEFORM SETTING
0	1		A ₇	A ₆	A ₅	A ₄	A ₃	A ₂	A ₁	A ₀		
0	1		B ₇	B ₆	B ₅	B ₄	B ₃	B ₂	B ₁	B ₀		
0	1		:	:	:	:	:	:	:	:		
0	1			
0	0	34	0	0	1	1	0	1	0	0	CRC calculation	CRC calculation command For details, please refer to SSD1681 application note. BUSY pad will output high during operation.
0	0	35	0	0	1	1	0	1	0	1	CRC Status Read	CRC Status Read A[15:0] is the CRC read out value
1	1		A ₁₅	A ₁₄	A ₁₃	A ₁₂	A ₁₁	A ₁₀	A ₉	A ₈		
1	1		A ₇	A ₆	A ₅	A ₄	A ₃	A ₂	A ₁	A ₀		

Command Table											Command	Description
R/W#	D/C#	Hex	D7	D6	D5	D4	D3	D2	D1	D0		
0	0	36	0	0	1	1	0	1	1	0	Program OTP selection	Program OTP Selection according to the OTP Selection Control [R37h and R38h] The command required CLKEN=1. Refer to Register 0x22 for detail. BUSY pad will output high during operation.
0	0	37	0	0	1	1	0	1	1	1	Write Register for Display Option	Write Register for Display Option A[7:0] Spare VCOM OTP selection 0: Default [POR] 1: Spare B[7:0] Display Mode for WS[7:0] C[7:0] Display Mode for WS[15:8] D[7:0] Display Mode for WS[23:16] E[7:0] Display Mode for WS[31:24] F[3:0] Display Mode for WS[35:32] 0: Display Mode 1 1: Display Mode 2 F[6]: PingPong for Display Mode 2 0: RAM Ping-Pong disable [POR] 1: RAM Ping-Pong enable G[7:0]~J[7:0] module ID /waveform version. Remarks: 1) A[7:0]~J[7:0] can be stored in OTP 2) RAM Ping-Pong function is not support for Display Mode 1
0	1		A ₇	0	0	0	0	0	0	0		
0	1		B ₇	B ₆	B ₅	B ₄	B ₃	B ₂	B ₁	B ₀		
0	1		C ₇	C ₆	C ₅	C ₄	C ₃	C ₂	C ₁	C ₀		
0	1		D ₇	D ₆	D ₅	D ₄	D ₃	D ₂	D ₁	D ₀		
0	1		E ₇	E ₆	E ₅	E ₄	E ₃	E ₂	E ₁	E ₀		
0	1		0	F ₆	0	0	F ₃	F ₂	F ₁	F ₀		
0	1		G ₇	G ₆	G ₅	G ₄	G ₃	G ₂	G ₁	G ₀		
0	1		H ₇	H ₆	H ₅	H ₄	H ₃	H ₂	H ₁	H ₀		
0	1		I ₇	I ₆	I ₅	I ₄	I ₃	I ₂	I ₁	I ₀		
0	1		J ₇	J ₆	J ₅	J ₄	J ₃	J ₂	J ₁	J ₀		
0	0	38	0	0	1	1	1	0	0	0	Write Register for User ID	Write Register for User ID A[7:0]~J[7:0]: UserID [10 bytes] Remarks: A[7:0]~J[7:0] can be stored in OTP
0	1		A ₇	A ₆	A ₅	A ₄	A ₃	A ₂	A ₁	A ₀		
0	1		B ₇	B ₆	B ₅	B ₄	B ₃	B ₂	B ₁	B ₀		
0	1		C ₇	C ₆	C ₅	C ₄	C ₃	C ₂	C ₁	C ₀		
0	1		D ₇	D ₆	D ₅	D ₄	D ₃	D ₂	D ₁	D ₀		
0	1		E ₇	E ₆	E ₅	E ₄	E ₃	E ₂	E ₁	E ₀		
0	1		F ₇	F ₆	F ₅	F ₄	F ₃	F ₂	F ₁	F ₀		
0	1		G ₇	G ₆	G ₅	G ₄	G ₃	G ₂	G ₁	G ₀		
0	1		H ₇	H ₆	H ₅	H ₄	H ₃	H ₂	H ₁	H ₀		
0	1		I ₇	I ₆	I ₅	I ₄	I ₃	I ₂	I ₁	I ₀		
0	1		J ₇	J ₆	J ₅	J ₄	J ₃	J ₂	J ₁	J ₀		
0	0	39	0	0	1	1	1	0	0	1	OTP program mode	OTP program mode A[1:0] = 00: Normal Mode [POR] A[1:0] = 11: Internal generated OTP programming voltage Remark: User is required to EXACTLY follow the reference code sequences
0	1		0	0	0	0	0	0	A ₁	A ₀		

Command Table											Command	Description																																			
R/W#	D/C#	Hex	D7	D6	D5	D4	D3	D2	D1	D0																																					
0	0	3C	0	0	1	1	1	1	0	0	Border Waveform Control	Select border waveform for VBD A[7:0] = C0h [POR], set VBD as HiZ. A [7:6] :Select VBD option																																			
0	1		A ₇	A ₆	A ₅	A ₄	0	A ₂	A ₁	A ₀			<table border="1"> <tr> <td>A[7:6]</td> <td>Select VBD as</td> </tr> <tr> <td>00</td> <td>GS Transition, Defined in A[2] and A[1:0]</td> </tr> <tr> <td>01</td> <td>Fix Level, Defined in A[5:4]</td> </tr> <tr> <td>10</td> <td>VCOM</td> </tr> <tr> <td>11[POR]</td> <td>HiZ</td> </tr> </table> A [5:4] Fix Level Setting for VBD <table border="1"> <tr> <td>A[5:4]</td> <td>VBD level</td> </tr> <tr> <td>00</td> <td>VSS</td> </tr> <tr> <td>01</td> <td>VSH1</td> </tr> <tr> <td>10</td> <td>VSL</td> </tr> <tr> <td>11</td> <td>VSH2</td> </tr> </table> A[2] GS Transition control <table border="1"> <tr> <td>A[2]</td> <td>GS Transition control</td> </tr> <tr> <td>0</td> <td>Follow LUT (Output VCOM @ RED)</td> </tr> <tr> <td>1</td> <td>Follow LUT</td> </tr> </table> A [1:0] GS Transition setting for VBD <table border="1"> <tr> <td>A[1:0]</td> <td>VBD Transition</td> </tr> <tr> <td>00</td> <td>LUT0</td> </tr> <tr> <td>01</td> <td>LUT1</td> </tr> <tr> <td>10</td> <td>LUT2</td> </tr> <tr> <td>11</td> <td>LUT3</td> </tr> </table>	A[7:6]	Select VBD as	00	GS Transition, Defined in A[2] and A[1:0]	01	Fix Level, Defined in A[5:4]	10	VCOM	11[POR]	HiZ	A[5:4]	VBD level	00	VSS	01	VSH1	10	VSL	11	VSH2	A[2]	GS Transition control	0	Follow LUT (Output VCOM @ RED)	1	Follow LUT	A[1:0]	VBD Transition	00	LUT0	01	LUT1	10	LUT2
A[7:6]	Select VBD as																																														
00	GS Transition, Defined in A[2] and A[1:0]																																														
01	Fix Level, Defined in A[5:4]																																														
10	VCOM																																														
11[POR]	HiZ																																														
A[5:4]	VBD level																																														
00	VSS																																														
01	VSH1																																														
10	VSL																																														
11	VSH2																																														
A[2]	GS Transition control																																														
0	Follow LUT (Output VCOM @ RED)																																														
1	Follow LUT																																														
A[1:0]	VBD Transition																																														
00	LUT0																																														
01	LUT1																																														
10	LUT2																																														
11	LUT3																																														
0	0	3F	0	0	1	1	1	1	1	1	End Option (EOPT)	Option for LUT end A[7:0]= 02h [POR]																																			
0	1		A ₇	A ₆	A ₅	A ₄	A ₃	A ₂	A ₁	A ₀			<table border="1"> <tr> <td>22h</td> <td>Normal.</td> </tr> <tr> <td>07h</td> <td>Source output level keep previous output before power off</td> </tr> </table>	22h	Normal.	07h	Source output level keep previous output before power off																														
22h	Normal.																																														
07h	Source output level keep previous output before power off																																														
0	0	41	0	1	0	0	0	0	0	1	Read RAM Option	Read RAM Option A[0]= 0 [POR] 0 : Read RAM corresponding to RAM0x24 1 : Read RAM corresponding to RAM0x26																																			
0	1		0	0	0	0	0	0	0	A ₀																																					
0	0	44	0	1	0	0	0	1	0	0	Set RAM X - address Start / End position	Specify the start/end positions of the window address in the X direction by an address unit for RAM A[5:0]: XSA[5:0], XStart, POR = 00h B[5:0]: XEA[5:0], XEnd, POR = 15h																																			
0	1		0	0	A ₅	A ₄	A ₃	A ₂	A ₁	A ₀																																					
0	1		0	0	B ₅	B ₄	B ₃	B ₂	B ₁	B ₀																																					
0	0	45	0	1	0	0	0	1	0	1	Set Ram Y- address Start / End position	Specify the start/end positions of the window address in the Y direction by an address unit for RAM A[8:0]: YSA[8:0], YStart, POR = 000h B[8:0]: YEA[8:0], YEnd, POR = 127h																																			
0	1		A ₇	A ₆	A ₅	A ₄	A ₃	A ₂	A ₁	A ₀																																					
0	1		0	0	0	0	0	0	0	A ₈																																					
0	1		B ₇	B ₆	B ₅	B ₄	B ₃	B ₂	B ₁	B ₀																																					
0	1		0	0	0	0	0	0	0	B ₈																																					

Command Table											Command	Description																																							
R/W#	D/C#	Hex	D7	D6	D5	D4	D3	D2	D1	D0																																									
0	0	46	0	1	0	0	0	1	1	0	Auto Write RED RAM for Regular Pattern	Auto Write RED RAM for Regular Pattern A[7:0] = 00h [POR]																																							
0	1		A ₇	A ₆	A ₅	A ₄	0	A ₂	A ₁	A ₀			A[7]: The 1st step value, POR = 0 A[6:4]: Step Height, POR= 000 Step of alter RAM in Y-direction according to Gate <table border="1"> <thead> <tr> <th>A[6:4]</th> <th>Height</th> <th>A[6:4]</th> <th>Height</th> </tr> </thead> <tbody> <tr> <td>000</td> <td>8</td> <td>100</td> <td>128</td> </tr> <tr> <td>001</td> <td>16</td> <td>101</td> <td>200</td> </tr> <tr> <td>010</td> <td>32</td> <td>110</td> <td>200</td> </tr> <tr> <td>011</td> <td>64</td> <td>111</td> <td>200</td> </tr> </tbody> </table> A[2:0]: Step Width, POR= 000 Step of alter RAM in X-direction according to Source <table border="1"> <thead> <tr> <th>A[2:0]</th> <th>Width</th> <th>A[2:0]</th> <th>Width</th> </tr> </thead> <tbody> <tr> <td>000</td> <td>8</td> <td>100</td> <td>128</td> </tr> <tr> <td>001</td> <td>16</td> <td>101</td> <td>200</td> </tr> <tr> <td>010</td> <td>32</td> <td>110</td> <td>200</td> </tr> <tr> <td>011</td> <td>64</td> <td>111</td> <td>200</td> </tr> </tbody> </table> BUSY pad will output high during operation.	A[6:4]	Height	A[6:4]	Height	000	8	100	128	001	16	101	200	010	32	110	200	011	64	111	200	A[2:0]	Width	A[2:0]	Width	000	8	100	128	001	16	101	200	010	32	110	200	011	64
A[6:4]	Height	A[6:4]	Height																																																
000	8	100	128																																																
001	16	101	200																																																
010	32	110	200																																																
011	64	111	200																																																
A[2:0]	Width	A[2:0]	Width																																																
000	8	100	128																																																
001	16	101	200																																																
010	32	110	200																																																
011	64	111	200																																																
0	0	47	0	1	0	0	0	1	1	1	Auto Write B/W RAM for Regular Pattern	Auto Write B/W RAM for Regular Pattern A[7:0] = 00h [POR]																																							
0	1		A ₇	A ₆	A ₅	A ₄	0	A ₂	A ₁	A ₀			A[7]: The 1st step value, POR = 0 A[6:4]: Step Height, POR= 000 Step of alter RAM in Y-direction according to Gate <table border="1"> <thead> <tr> <th>A[6:4]</th> <th>Height</th> <th>A[6:4]</th> <th>Height</th> </tr> </thead> <tbody> <tr> <td>000</td> <td>8</td> <td>100</td> <td>128</td> </tr> <tr> <td>001</td> <td>16</td> <td>101</td> <td>200</td> </tr> <tr> <td>010</td> <td>32</td> <td>110</td> <td>200</td> </tr> <tr> <td>011</td> <td>64</td> <td>111</td> <td>200</td> </tr> </tbody> </table> A[2:0]: Step Width, POR= 000 Step of alter RAM in X-direction according to Source <table border="1"> <thead> <tr> <th>A[2:0]</th> <th>Width</th> <th>A[2:0]</th> <th>Width</th> </tr> </thead> <tbody> <tr> <td>000</td> <td>8</td> <td>100</td> <td>128</td> </tr> <tr> <td>001</td> <td>16</td> <td>101</td> <td>200</td> </tr> <tr> <td>010</td> <td>32</td> <td>110</td> <td>200</td> </tr> <tr> <td>011</td> <td>64</td> <td>111</td> <td>200</td> </tr> </tbody> </table> During operation, BUSY pad will output high.	A[6:4]	Height	A[6:4]	Height	000	8	100	128	001	16	101	200	010	32	110	200	011	64	111	200	A[2:0]	Width	A[2:0]	Width	000	8	100	128	001	16	101	200	010	32	110	200	011	64
A[6:4]	Height	A[6:4]	Height																																																
000	8	100	128																																																
001	16	101	200																																																
010	32	110	200																																																
011	64	111	200																																																
A[2:0]	Width	A[2:0]	Width																																																
000	8	100	128																																																
001	16	101	200																																																
010	32	110	200																																																
011	64	111	200																																																
0	0	4E	0	1	0	0	1	1	1	0	Set RAM X address counter	Make initial settings for the RAM X address in the address counter (AC) A[5:0]: 00h [POR].																																							
0	1		0	0	A ₅	A ₄	A ₃	A ₂	A ₁	A ₀																																									
0	0	4F	0	1	0	0	1	1	1	1	Set RAM Y address counter	Make initial settings for the RAM Y address in the address counter (AC) A[8:0]: 000h [POR].																																							
0	1		A ₇	A ₆	A ₅	A ₄	A ₃	A ₂	A ₁	A ₀																																									
0	1		0	0	0	0	0	0	0	A ₈																																									
0	0	7F	0	1	1	1	1	1	1	1	NOP	This command is an empty command; it does not have any effect on the display module. However it can be used to terminate Frame Memory Write or Read Commands.																																							

7. Electrical Characteristics

7-1. Absolute maximum rating

Parameter	Symbol	Rating	Unit
Logic supply voltage	V _{CI}	-0.5 to +4.0	V
Logic Input voltage	V _{IN}	-0.5 to V _{CI} +0.5	V
Logic Output voltage	V _{OUT}	-0.5 to V _{CI} +0.5	V
Operating Temp range	TOPR	0 to +50	°C
Storage Temp range	TSTG	-25 to +70	°C
Optimal Storage Temp	TSTGo	23±2	°C
Optimal Storage Humidity	HSTGo	55±10	%RH

7-2. Panel DC Characteristics

The following specifications apply for: V_{SS}=0V, V_{CI}=3.0V, TOPR =23°C

Parameter	Symbol	Conditions	Applicable pin	Min.	Typ.	Max	Units
Single ground	V _{SS}	-		-	0	-	V
Logic supply voltage	V _{CI}	-	V _{CI}	2.2	3.0	3.7	V
Core logic voltage	V _{DD}		V _{DD}	1.7	1.8	1.9	V
High level input voltage	V _{IH}	-	-	0.8 V _{CI}	-	-	V
Low level input voltage	V _{IL}	-	-	-	-	0.2 V _{CI}	V
High level output voltage	V _{OH}	I _{OH} = -100uA	-	0.9 V _{CI}	-	-	V
Low level output voltage	V _{OL}	I _{OL} = 100uA	-	-	-	0.1 V _{CI}	V
Typical power	P _{TYP}	V _{CI} =3.0V	-	-	4.5	-	mW
Deep sleep mode	P _{STPY}	V _{CI} =3.0V	-	-	0.003	-	mW
Typical operating current	I _{opr_VCI}	V _{CI} =3.0V	-	-	1.5	-	mA
Full update time	-	25 °C	-	-	2	-	sec
Fast update time	-	25 °C	-	-	1.5	-	sec
Partial update time	-	25 °C	-	-	0.26	-	sec
Sleep mode current	I _{slp_VCI}	DC/DC off No clock No input load Ram data retain	-	-	20	-	uA
Deep sleep mode current	I _{dslp_VCI}	DC/DC off No clock No input load Ram data not retain	-	-	1	5	uA

Notes:

- 1) Refresh time: the time it takes for the whole process from the screen change to the screen stabilization.
- 2) The difference between different refresh methods:
Full refresh: The screen will flicker several times during the refresh process;

Fast Refresh: The screen will flash once during the refresh process;

Partial refresh: The screen does not flicker during the refresh process.

Note: During the fast refresh or partial refresh of the electronic paper, it is recommended to add a full-screen refresh after 5 consecutive operations to reduce the accumulation of afterimages on the screen.

The Typical power consumption is measured with following pattern transition: from horizontal 2 gray scale pattern to vertical 2 gray scale pattern.(Note 7-1)The standby power is the consumed power when the panel controller is in standby mode. The listed electrical/optical characteristics are only guaranteed under the controller & waveform provided by GOOD DISPLAY Vcom is recommended to be set in the range of assigned value $\pm 0.1V$.

Note 7-1 The Typical power consumption



7-3. Panel AC Characteristics

7-3-1. MCU Interface

7-3-1-1. MCU Interface selection

The module can support 3-wire/4-wire serial peripheral. MCU interface is pin selectable by BS1 shown in Table 7-1.

MCU Interface	Pin Name					
	BS1	RES#	CS#	D/C#	SCL	SDA
4-wire serial peripheral interface (SPI)	L	RES#	CS#	DC#	SCL	SDA
3-wire serial peripheral interface (SPI) – 9 bits SPI	H	RES#	CS#	L	SCL	SDA

Table 7-1 : Interface pins assignment under different MCU interface

Note:(1) L is connected to VSS and H is connected to VDDIO

7-3-1-2. MCU Serial Interface (4-wire SPI)

The 4-wire SPI consists of serial clock SCL, serial data SDA, D/C# and CS#. The control pins status in 4-wire SPI in writing command/data is shown in Table 6-2 and the write procedure 4-wire SPI is shown in Table 7-2

Function	SCL pin	SDA pin	D/C# pin	CS# pin
Write command	↑	Command bit	L	L
Write data	↑	Data bit	H	L

Table 7-2 : Control pins status of 4-wire SPI

Note:

- (1) L is connected to VSS and H is connected to VDDIO
- (2) ↑ stands for rising edge of signal
- (3) SDA (Write Mode) is shifted into an 8-bit shift register on every rising edge of SCL in the order of D7, D6, ... D0. The level of D/C# should be kept over the whole byte. The data byte in the shift register is written to the Graphic Display Data RAM (RAM)/Data Byte register or command Byte register according to D/C# pin.

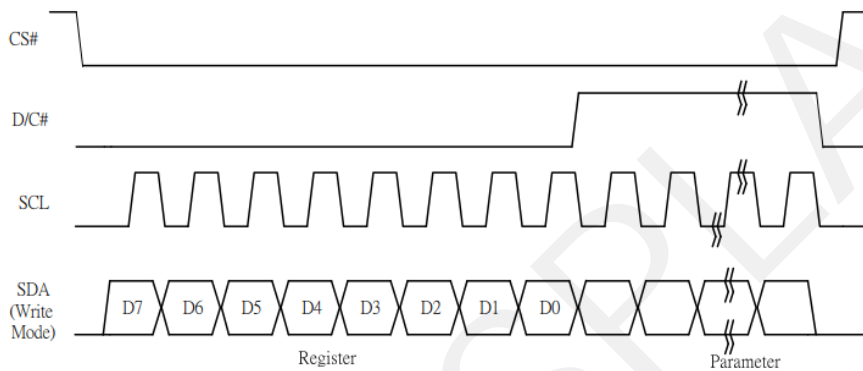

Figure 7-1 : Write procedure in 4-wire SPI mode

In the read operation (Command 0x1B, 0x27, 0x2D, 0x2E, 0x2F, 0x35). After CS# is pulled low, the first byte sent is command byte, D/C# is pulled low. After command byte sent, the following byte(s) read are data byte(s), so D/C# bit is then pulled high. An 8-bit data will be shifted out on every clock falling edge. The serial data SDA bit shifting sequence is D7, D6, to D0 bit. Figure 6-2 shows the read procedure in 4-wire SPI.

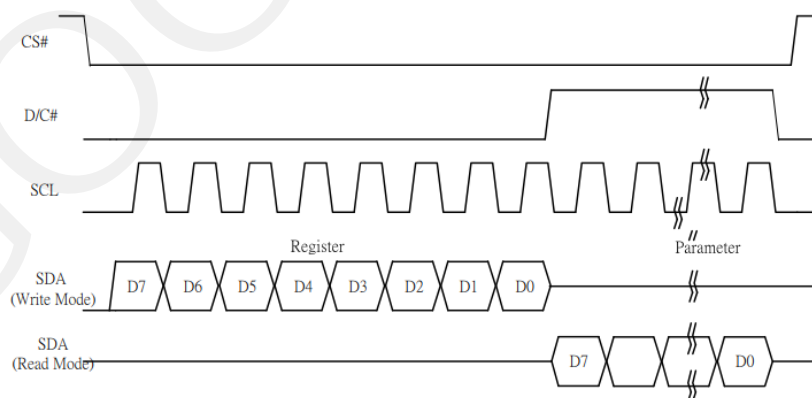

Figure 7-2 : Read procedure in 4-wire SPI mode

7-3-1-3. MCU Serial Peripheral Interface (3-wire SPI)

The 3-wire SPI consists of serial clock SCL, serial data SDA and CS#. The operation is similar to 4-wire SPI while D/C# pin is not used and it must be tied to LOW. The control pins status in 3-wire SPI is shown in Table 7-3.

In the write operation, a 9-bit data will be shifted into the shift register on every clock rising edge. The bit shifting sequence is D/C# bit, D7 bit, D6 bit to D0 bit. The first bit is D/C# bit which determines the following byte is command or data. When D/C# bit is 0, the following byte is command. When D/C# bit is 1, the following byte is data. Table 6-3 shows the write procedure in 3-wire SPI

Function	SCL pin	SDA pin	D/C# pin	CS# pin
Write command	↑	Command bit	Tie LOW	L
Write data	↑	Data bit	Tie LOW	L

Table 7-3 : Control pins status of 3-wire SPI

Note:

- (1) L is connected to VSS and H is connected to VDDIO
- (2) ↑ stands for rising edge of signal

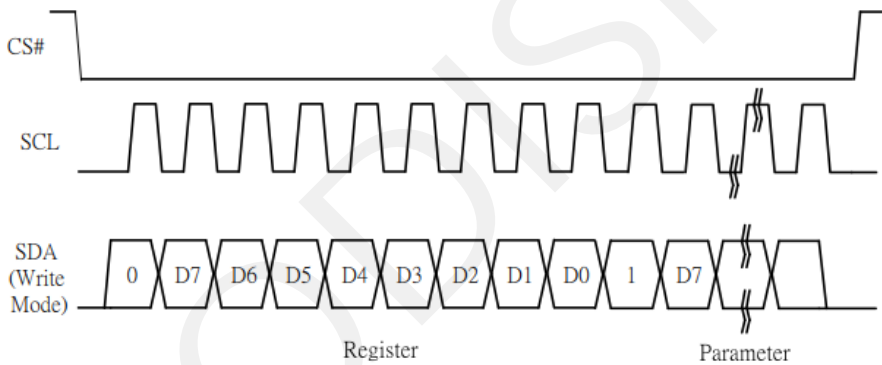

Figure 7-3 : Write procedure in 3-wire SPI

In the read operation (Register 0x1B, 0x27, 0x2D, 0x2E, 0x2F, 0x35). SDA data are transferred in the unit of 9 bits. After CS# pull low, the first byte is command byte, the D/C# bit is as 0 and following with the register byte. After command byte send, the following byte(s) are data byte(s), with D/C# bit is 1. After D/C# bit sending from MCU, an 8-bit data will be shifted out on every clock falling edge. The serial data SDA bit shifting sequence is D7, D6, to D0 bit. Figure 7-4 shows the read procedure in 3-wire SPI.

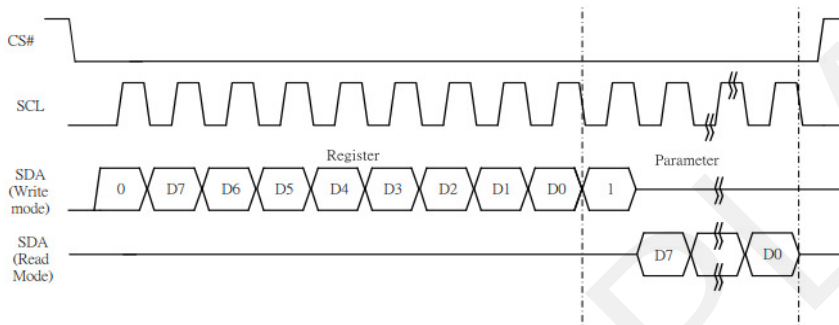

Figure 7-4 : Read procedure in 3-wire SPI mode

7-3-2. Serial Peripheral Interface

Write mode

Symbol	Parameter	Min	Typ	Max	Unit
f _{SCL}	SCL frequency (Write Mode)	-	-	20	MHz
t _{CSSU}	Time CS# has to be low before the first rising edge of SCLK	60	-	-	ns
t _{CSHLD}	Time CS# has to remain low after the last falling edge of SCLK	65	-	-	ns
t _{CSHIGH}	Time CS# has to remain high between two transfers	100	-	-	ns
t _{SCLHIGH}	Part of the clock period where SCL has to remain high	25	-	-	ns
t _{SCLLOW}	Part of the clock period where SCL has to remain low	25	-	-	ns
t _{SISU}	Time SI (SDA Write Mode) has to be stable before the next rising edge of SCL	10	-	-	ns
t _{SIHLD}	Time SI (SDA Write Mode) has to remain stable after the rising edge of SCL	40	-	-	ns

Read mode

Symbol	Parameter	Min	Typ	Max	Unit
f _{SCL}	SCL frequency (Read Mode)	-	-	2.5	MHz
t _{CSSU}	Time CS# has to be low before the first rising edge of SCLK	100	-	-	ns
t _{CSHLD}	Time CS# has to remain low after the last falling edge of SCLK	50	-	-	ns
t _{CSHIGH}	Time CS# has to remain high between two transfers	250	-	-	ns
t _{SCLHIGH}	Part of the clock period where SCL has to remain high	180	-	-	ns
t _{SCLLOW}	Part of the clock period where SCL has to remain low	180	-	-	ns
t _{SOSU}	Time SO(SDA Read Mode) will be stable before the next rising edge of SCL	-	50	-	ns
t _{SOHLD}	Time SO (SDA Read Mode) will remain stable after the falling edge of SCL	-	0	-	ns

Note: All timings are based on 20% to 80% of VDDIO-VSS

Table 7-4: Serial Peripheral Interface Timing Characteristics

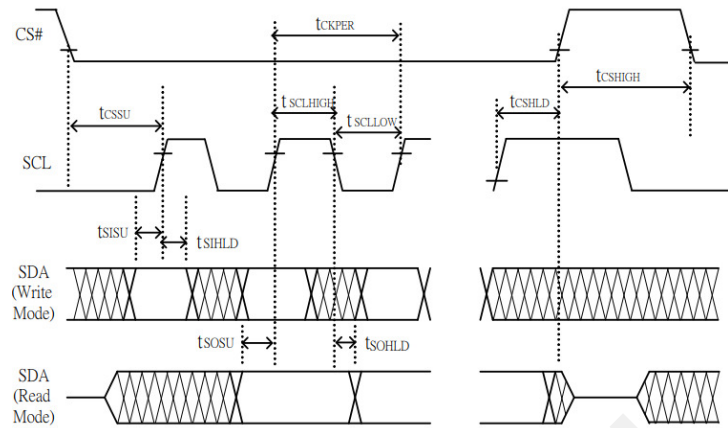

Figure 7-5: SPI timing diagram

8. Optical Specifications

8.1. Specifications

Measurements are made with that the illumination is under an angle of 45 degree, the detection is perpendicular unless otherwise specified

Symbol	Parameter	Conditions	Min	Typ.	Max	Units	Notes
R	White Reflectivity	White	30	35	-	%	8-1
CR	Contrast Ratio	Indoor	8:1		-		8-2
GN	2Grey Level	-		$DS+(WS-DS)*n(m-1)$			8-3
T update	Image update time	at 25 °C		3	-	sec	
Life		Topr		1000000times or 5years			

Notes:

8-1. Luminance meter: Eye-One Pro Spectrophotometer.

8-2. CR=Surface Reflectance with all white pixel/Surface Reflectance with all black pixels.

8-3. WS: White state, DS: Dark state

9. Reference Circuit

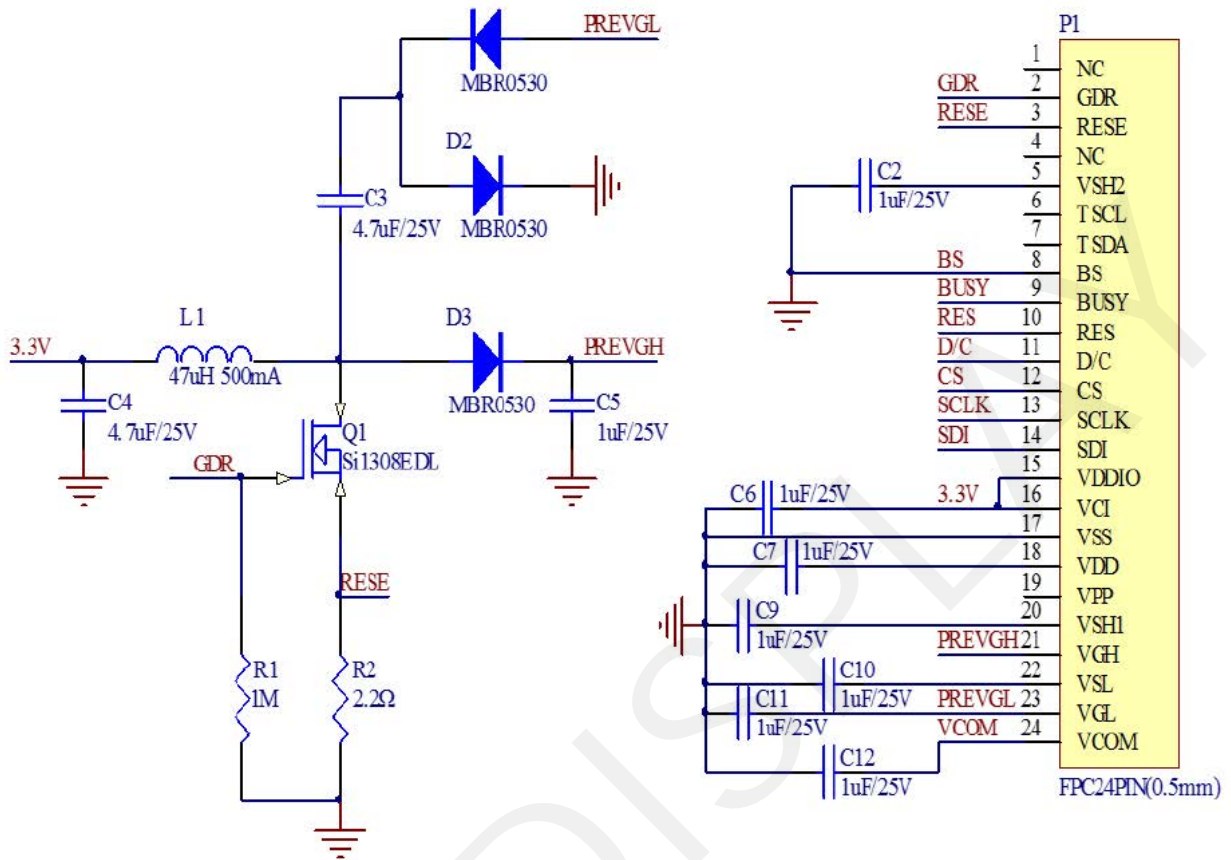

10. Matched Development Kit

Our Development Kit designed for SPI E-paper Display aims to help users to learn how to use E-paper Display more easily. It can refresh black-white E-paper Display, three-color (black, white and red/Yellow) E-paper Display and four-color(black, white, red and yellow) Good Display `s E-paper Display. And it is also added the functions of USB serial port, FLASH chip, font chip, current detection ect.

Development Kit consists of the development board and the pinboard.

Supported development platforms include STM32, ESP32, ESP8266, Arduino UNO, etc. More details, please click to the following links:

STM32 <https://www.good-display.com/product/219.html>

ESP32 <https://www.good-display.com/product/338.html>

ESP8266 <https://www.good-display.com/product/220.html>

Arduino UNO <https://www.good-display.com/product/222.html>

GOOD DISPLAY

11. Reliability test

NO	Test items	Test condition
1	Low-Temperature Storage	T = -25 °C, 240 h Test in white pattern
2	High-Temperature Storage	T=70° C, RH=40%, 240h Test in white pattern
3	High-Temperature Operation	T=50° C, RH=35%, 240h
4	Low-Temperature Operation	0° C, 240h
5	High-Temperature, High-Humidity Operation	T=40° C, RH=80%, 240h
6	High Temperature, High Humidity Storage	T=50° C, RH=80%, 240h Test in white pattern
7	Temperature Cycle	1 cycle:[-25° C 30min]→[+70 ° C 30 min] : 50 cycles Test in white pattern
8	UV exposure Resistance	765W/m ² for 168hrs,40 °C Test in white pattern
9	ESD Gun	Air+/-15KV;Contact+/-8KV (Test finished product shell, not display only) Air+/-8KV;Contact+/-6KV (Naked EPD display, no including IC and FPC area) Air+/-4KV;Contact+/-2KV (Naked EPD display, including IC and FPC area)

Note: Put in normal temperature for 1hour after test finished, display performance is ok.

12. Typical Operating Sequence

12.1 Normal Operation Flow

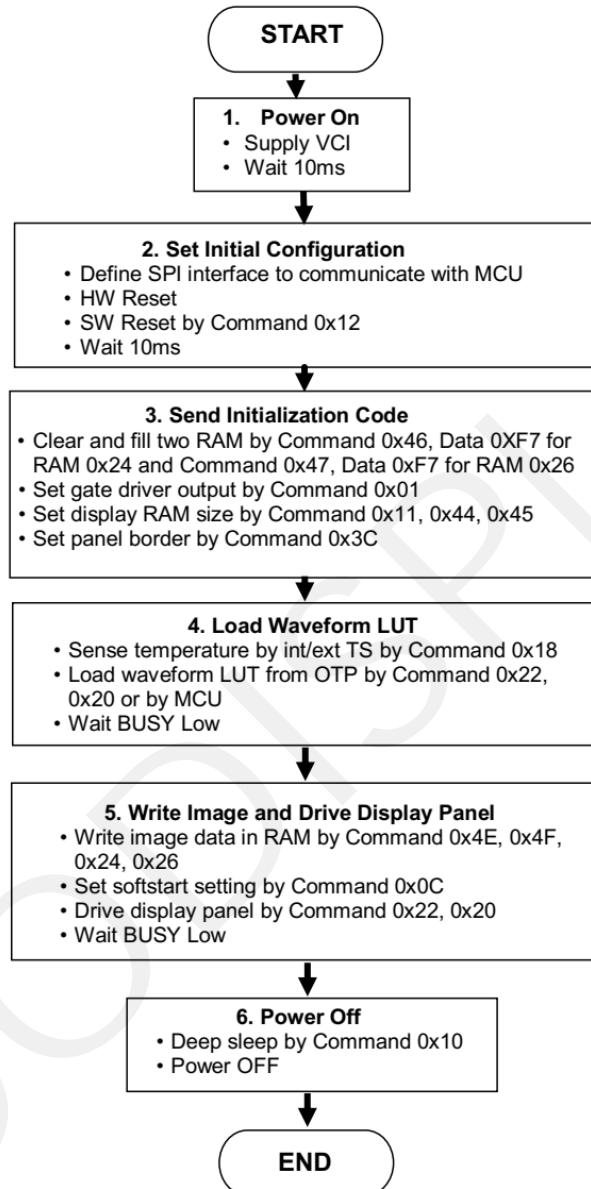

13. Inspection method and condition

13.1 Inspection condition

Item	Condition
Illuminance	≥1000 lux
Temperature	22°C ±3°C
Humidity	45-65 % RoHS
Distance	≥30cm
Angle	±45 °
Inspection method	By eyes

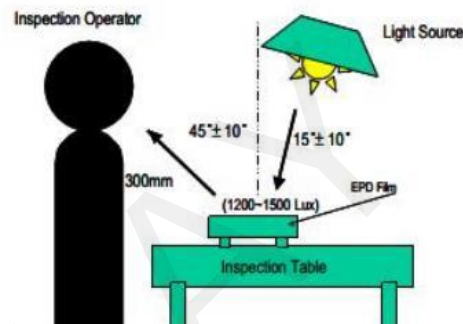

13.2 Display area

13.2.1 Zone definition:

- A Zone: Active area
- B Zone: Border zone
- C Zone: From B zone edge to panel edge

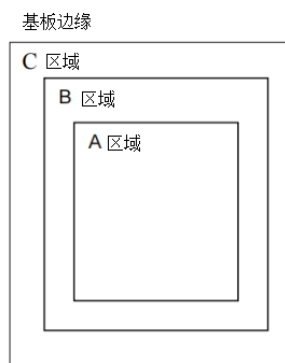



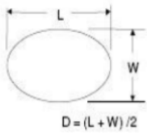
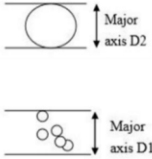

13.3 General inspection standards for products

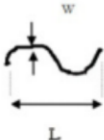
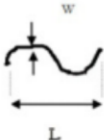

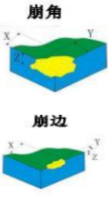
13.3.1 Appearance inspection standard



Inspection item		Figure		A zone inspection standard	B/C zone	Inspection method	MAJ/ MIN
Spot defects	Spot defects such as dot, foreign matter, air bubble, and dent etc.	Diameter $D=(L+W)/2$ (L-length, W-width) Measuring method shown in the figure below 	A spec module The distance between the two spots should not be less than 10mm	7.5"-13.3"Module (Not include 7.5") : $D > 1\text{mm}$ N=0 $0.5 < D \leq 0.8$ $N \leq 4$ $D \leq 0.5$ Ignore $0.8 < D \leq 1$ $N \leq 2$ 4.2"-7.5"Module (Not include 4.2") : $D > 0.5$ N=0 $0.4 < D \leq 0.5$ $N \leq 2$ $D \leq 0.25$ Ignore $0.25 < D \leq 0.4$ $N \leq 4$ Module below 4.2": $D > 0.5$ N=0 $0.4 < D \leq 0.5$ $N \leq 1$ $D \leq 0.25$ Ignore $0.25 < D \leq 0.4$ $N \leq 4$ $0.1\text{mm} < D \leq 0.25$ $N \leq 3/\text{cm}^2$	Foreign matter D ≤ 1mm Pass	Check by eyes Film gauge	MIN
			B spec module The distance between the two spots should not be less than 5mm (Outside the AA area, ignore if not serious when checking by eyes)	No affect on display			

Inspection item		Figure		A zone inspection standard	B/C zone	Inspection method	MAJ/ MIN
Line defects	Line defects such as scratch, hair etc.	L-Length, W-Width, $(W/L) < 1/4$ Judged by line, $(W/L) \geq 1/4$ Judged by dot 	A spec module The distance between the two lines should not be less than 5mm	7.5"-13.3"Module (Not include 7.5") : $L > 10\text{mm}, N=0$ $W > 0.8\text{mm}, N=0$ $5\text{mm} \leq L \leq 10\text{mm}, 0.5\text{mm} \leq W \leq 0.8\text{mm}$ $N \leq 2$ $L \leq 5\text{mm}, W \leq 0.5\text{mm}$ Ignore 4.2"-7.5"Module (Not include 4.2") : $L > 8\text{mm}, N=0$ $W > 0.2\text{mm}, N=0$ $2\text{mm} \leq L \leq 8\text{mm}, 0.1\text{mm} \leq W \leq 0.2\text{mm}$ $N \leq 4$ $L \leq 2\text{mm}, W \leq 0.1\text{mm}$ Ignore Module below 4.2": $L > 5\text{mm}, N=0$ $W > 0.2\text{mm}, N=0$ $2\text{mm} \leq L \leq 5\text{mm}, 0.1\text{mm} \leq W \leq 0.2\text{mm}$ $N \leq 4$ $L \leq 2\text{mm}, W \leq 0.1\text{mm}$ Ignore	Ignore	Check by eyes Film gauge	MIN
			B spec module The distance between the two lines should not be less than 5mm (Outside the AA area, ignore if not serious when checking by eyes)	No affect on display			

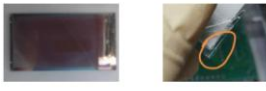
Inspection item		Figure	Inspection standard	Inspection method	MAJ / MIN
Panel chipping and crack defects	TFT panel chipping	<p>X the length, Y the width, Z the chipping height, T the thickness of the panel</p> 	<p>Chipping at the edge: Module over 7.5" (Include 7.5") : $X \leq 6\text{mm}, Y \leq 1\text{mm}, Z \leq T, N=3$ Allowed</p> <p>Module below 7.5"(Not include 7.5"): $X \leq 3\text{mm}, Y \leq 1\text{mm}, Z \leq T, N=3$ Allowed</p> <p>Chipping on the corner: IC side $X \leq 2\text{mm}, Y \leq 2\text{mm}$, Non-IC side $X \leq 1\text{mm}, Y \leq 1\text{mm}$. Allowed</p> <p>Note: 1、 Chipping should not damage the edge wiring. If it does not affect the display, allowed 2、 The size of the chipping is larger than the above conditions but the display is normal, it can be taken as the B spec.</p>	Check by eyes, Film gauge	MIN
	Crack		Crack at any zone of glass, Not allowed	Check by eyes, Film gauge	MIN
	Burr edge		No exceed the positive and negative deviation of the outline dimensions $X+Y \leq 0.2\text{mm}$ Allowed	Calliper	MIN
	Curl of panel		Curl height $H \leq \text{Total panel length } 1\%$ Allowed	Check by eyes	MIN

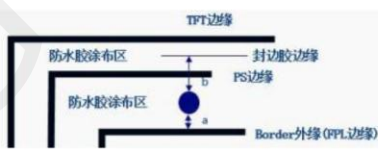
Remarks: The total number of defects in a single piece of A-spec glass is not allowed to exceed 4.

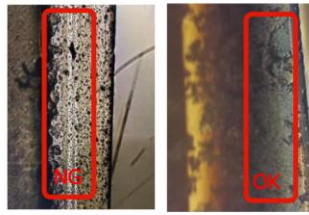
Inspection item		Figure	Inspection standard	Inspection method	MAJ / MIN
PS defect	Water proof film		<p>1. Waterproof film damage, wrinkled, open edge, not allowed</p> <p>2. Exceeding the edge of module (according to the lamination drawing) Not allowed</p> <p>3. Edge warped exceeds height of technical file, not allowed</p>	Check by eyes	MIN
RTV defect	Adhesive effect		Adhesive height exceeds the display surface, not allowed	Check by eyes	MIN
			<p>1. Overflow, exceeds the panel side edge, affecting the size, not allowed</p> <p>2. No adhesive at panel edge $\leq 1\text{mm}$, no exposure of wiring, allowed</p> <p>3. No adhesive at edge and corner $1*1\text{mm}$, no exposure of wiring, allowed</p>		
	Adhesive re-fill		Protection adhesive, coverage width within $W \leq 1.5\text{mm}$, no break of adhesive, allowed	Check by eyes	MIN
EC defect	Adhesive bubble		<p>1、 Effective edge sealing area of hot melt products $\geq 1/2$ edge sealing area;</p> <p>2、 Bubble $a+b/2 \geq 1/2$ effective width, $N \leq 3$, spacing $\geq 5\text{mm}$, allowed</p> <p>No exposure of wiring, allowed</p>	Check by eyes	MIN

Inspection item		Figure	Inspection standard	Inspection method	MAJ/MIN
EC defect	Adhesive effect		1. Overflow, exceeds the panel side edge, affecting the size, not allowed 2. No adhesive at panel edge $\leq 1\text{mm}$, no exposure of wiring, allowed 3. No adhesive at edge and corner $1*1\text{mm}$, no exposure of wiring, allowed 4. Adhesive height exceeds the display surface, not allowed	Visual, caliper	MIN
Silver dot adhesive defect	Silver dot adhesive		1. Single silver dot dispensing amount $\geq 1\text{mm}$, allowed 2. One of the double silver dot dispensing amount is $\geq 1\text{mm}$ and the other has adhesive (no reference to 1mm) Allowed	Visual	MIN
			Silver dot dispensing residue on the panel $\leq 0.2\text{mm}$, allowed	Film gauge	MIN
FPC defect	FPC wiring		FPC, TCP damage / gold finger peroxidation, adhesive residue, not allowed	Visual	MIJ
	FPC golden finger		The height of burr edge of TCP punching surface $\cong 0.4\text{mm}$, not allowed	Caliper	MIN
	FPC damage/cr ease		Damage and breaking, not allowed Crease does not affect the electrical performance display, allowed	Check by eyes	MIN

Inspection item		Figure	Inspection standard	Inspection method	MAJ/MIN
Protective film defect	Protective film		Scratch and crease on the surface but no affect to protection function, allowed	Check by eyes	MIN
			Adhesive at edge $L \leq 5\text{mm}$, $W \leq 0.5\text{mm}$, $N=2$, no entering into viewing area	Check by eyes	MIN
Stain defect	Stain		If stain can be normally wiped clean by $> 99\%$ alcohol, allowed	Visual	MIN
Pull tab defect	Pull tab		The position and direction meet the document requirements, and ensure that the protective film can be pulled off.	Check by eyes/ Manual pulling	MIN
Shading tape defect	Shading tape		Tilt $\leq 10^\circ$, flat without warping, completely covering the IC.	Check by eyes/ Film gauge	MIN
Stiffener	Stiffener		Flat without warping, Exceeding the left and right edges of the FPC is not allowed. Left and right can be less than 0.5mm from FPC edge	Check by eyes	MIN
Label	Label/ Spraying code		The content meets the requirements of the work sheet. The attaching position meets the requirements of the technical documents.	Check by eyes	MIN

Remarks: The definition of other appearance B spec products, no affect to the display, and no entering into the viewing area.

14. Handling, Safety and Environmental Requirements

WARNING

The display glass may break when it is dropped or bumped on a hard surface. Handle with care.
Should the display break, do not touch the electrophoretic material. In case of contact with electrophoretic material, wash with water and soap.

CAUTION

The display module should not be exposed to harmful gases, such as acid and alkali gases, which corrode electronic components.

Disassembling the display module can cause permanent damage and invalidate the warranty agreements.

Observe general precautions that are common to handling delicate electronic components. The glass can break and front surfaces can easily be damaged. Moreover the display is sensitive to static electricity and other rough environmental conditions.

Data sheet status

Product specification	The data sheet contains final product specifications.
-----------------------	---

Limiting values

Limiting values given are in accordance with the Absolute Maximum Rating System (IEC 134).

Stress above one or more of the limiting values may cause permanent damage to the device.

These are stress ratings only and operation of the device at these or any other conditions above those given in the Characteristics sections of the specification is not implied. Exposure to limiting values for extended periods may affect device reliability.

Application information

Where application information is given, it is advisory and does not form part of the specification.

Product Environmental certification

RoHS

15. Packaging

CUSTOMER'S APPROVED:

PAGE: 1/1

PACKLING ORDER:

1) Putting 35 pcs Modules on each PET tray. And cover a dedicated EPE film.

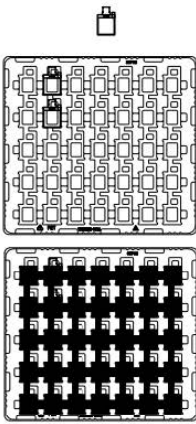

2) Putting 12 pcs PET trays together with 1 empty tray on the top of PET tray. Insert in the ESD bag, add desiccant in the ESD bag.

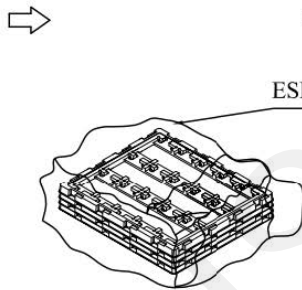

3) the tray together with adhesive tape

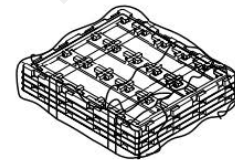

4) Putting into one outcarton

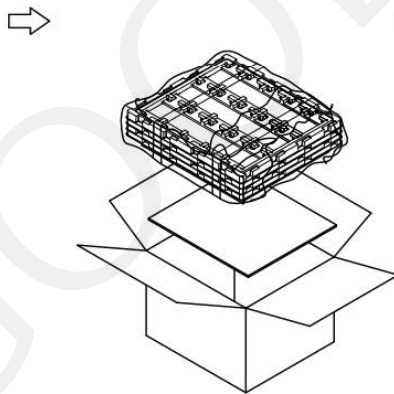

5) Packing finished

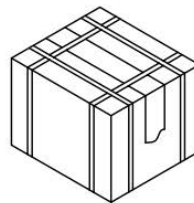

Note: 35 pcs in a tray, 12 trays in a inner carton, 1 inner cartons in a out carton, so 35x12x1=420pcs/Outcarton

Dimension (Out carton): 394*344*255mm

Drw:

Chk:

Apv:

16. Precautions

- (1) Do not apply pressure to the EPD panel in order to prevent damaging it.
- (2) Do not connect or disconnect the interface connector while the EPD panel is in operation.
- (3) Do not touch IC bonding area. It may scratch TFT lead or damage IC function.
- (4) Please be mindful of moisture to avoid its penetration into the EPD panel, which may cause damage during operation.
- (5) If the EPD Panel / Module is not refreshed every 24 hours, a phenomena known as "Ghosting" or "Image Sticking" may occur. It is recommended to refreshed the ESL / EPD Tag every 24 hours in use case. It is recommended that customer ships or stores the ESL / EPD Tag with a completely white image to avoid this issue
- (6) High temperature, high humidity, sunlight or fluorescent light may degrade the EPD panel's performance. Please do not expose the unprotected EPD panel to high temperature, high humidity, sunlight, or fluorescent for long periods of time.

<https://www.good-display.com/news/80.html>