



# INDIESEMIC

## Datasheet

### ISC-nRF52810-A

Multiprotocol BLE, ANT, 2.4GHz module

V0.2

## Table of Contents

1. General Description .....	3
2. Features .....	4
3. Applications .....	7
4. Application Block Diagram .....	8
5. Interfaces .....	9
Power Supply .....	9
System Function Interfaces .....	9
GPIOs .....	9
Two-wire Interface(I2CCompatible) .....	10
Flash Program I/Os .....	10
Serial Peripheral Interface .....	10
UARTs .....	11
Analogue to Digital Converter(ADC) .....	12
Reset .....	12
6. Module Specifications .....	13
7. Module Pin-out and Pin Description .....	14
Module Pin-out .....	14
Pin Footprint .....	14
Pin Description .....	14
8. Electrical Characteristics .....	16
Absolute Maximum Ratings .....	16
Recommended Operating Ratings .....	16
Current Ratings .....	17
9. Ordering Information .....	18

## 1. General Description

The module ISC\_nRF52810\_A is a powerful, highly flexible, ultra-low power Bluetooth Low Energy module using Nordic nRF52810 SoC solution developed by Indiesemic. This module supports BLE 5.3 standards. With an ARM Cortex M4 Processor available, it provides 192kB Flash, 24kBRAM, embedded 2.4GHz multiprotocol transceiver and an integrated PCB trace antenna.

The module incorporates: GPIO, SPI, UART, I2C, I2S, PMD, PWM, ADC interfaces for connecting peripherals and sensors.



## 2. Features

<p><b>2.4GHz transceiver</b></p>	<ul style="list-style-type: none"> <li>• -96 dBm sensitivity in Bluetooth® low energy mode</li> <li>• Supported data rates: 1 Mbps, 2 Mbps Bluetooth® low energy mode</li> <li>• -20 to +4dBm TX power, Configurable in 4dBsteps</li> <li>• On-chip balun (single-ended RF)</li> <li>• 4.6mA peak current in TX(0 dBm)</li> <li>• 4.6mA peak current in RX</li> <li>• RSSI(1 dB resolution)</li> </ul>
<p><b>ARM® Cortex®-M4 32-bit processor,64MHz</b></p>	<ul style="list-style-type: none"> <li>• 144 EEMBC Core Mark® score running from flash memory</li> <li>• 34.4µA/MHz running from Flash memory</li> <li>• 32.8µA/MHz running from RAM</li> <li>• Serial wire debug(SWD)</li> </ul>
<p><b>Flexible power management</b></p>	<ul style="list-style-type: none"> <li>• 1.7 V-3.6 V supply voltage range</li> <li>• Fully automatic LDO and DC/DC regulator system</li> </ul>

	<ul style="list-style-type: none"> <li>• Fast wake-up using 64 MHz internal oscillator</li> <li>• 0.3<math>\mu</math>A at 3V in System OFF mode, no RAM retention</li> <li>• 0.5<math>\mu</math>A at 3V in System OFF mode with full 24 kB RAM retention</li> <li>• 1.5<math>\mu</math>A at 3V in System ON mode, with full 24 kB RAM retention</li> </ul>
<p><b>Memory</b></p>	<ul style="list-style-type: none"> <li>• 192kBflash/24kBRAM</li> </ul>
<p><b>Other features</b></p>	<ul style="list-style-type: none"> <li>• Microprocessor Control Unit (MCU): nRF52810</li> <li>• Nordic Soft Device ready</li> <li>• Support for concurrent multi-protocol</li> <li>• 12-bit,200kSPSADC-8 configurable channels with programmable gain</li> <li>• 64 level Comparator</li> <li>• Temperature sensor</li> <li>• Up to 15 general purpose I/O pins</li> <li>• 4-channel pulse width modulator(PWM) unit with Easy DMA</li> </ul>

	<ul style="list-style-type: none"><li>• Digital microphone interface (PDM)</li><li>• 3x32-bit timer with counter mode</li><li>• SPI master/slave with Easy DMA</li><li>• I2C compatible 2-wire master/slave</li><li>• UART(CTS/RTS) with Easy DMA</li><li>• Programmable peripheral interconnect (PPI)</li><li>• Quadrature decoder(QDEC)</li><li>• AESHW encryption with Easy DMA</li><li>• 2xreal-timecounter(RTC)</li></ul>
--	--

CONFIDENTIAL

### 3. Applications

Due to varied support of protocols and stacks, the BLE module nRF52810 can support varied applications. A brief of the applications is as below:

<b>Internet of Things</b>	<ul style="list-style-type: none"> <li>• Smart home products</li> <li>• Industrial mesh networks</li> <li>• Smart city infrastructure</li> </ul>
<b>Advanced Wearables</b>	<ul style="list-style-type: none"> <li>• Connected watches</li> <li>• Advanced personal fitness devices</li> <li>• Wearables with wireless payment</li> <li>• Connected health</li> <li>• Virtual/Augmented reality applications</li> </ul>
<b>Interactive Entertainment Devices</b>	<ul style="list-style-type: none"> <li>• Advanced remote controls</li> <li>• Gaming controller</li> </ul>
<b>Personal Area Networks</b>	<ul style="list-style-type: none"> <li>• Health/Fitness sensor and monitor device</li> <li>• Medical device</li> </ul>

### 4. Application Block Diagram

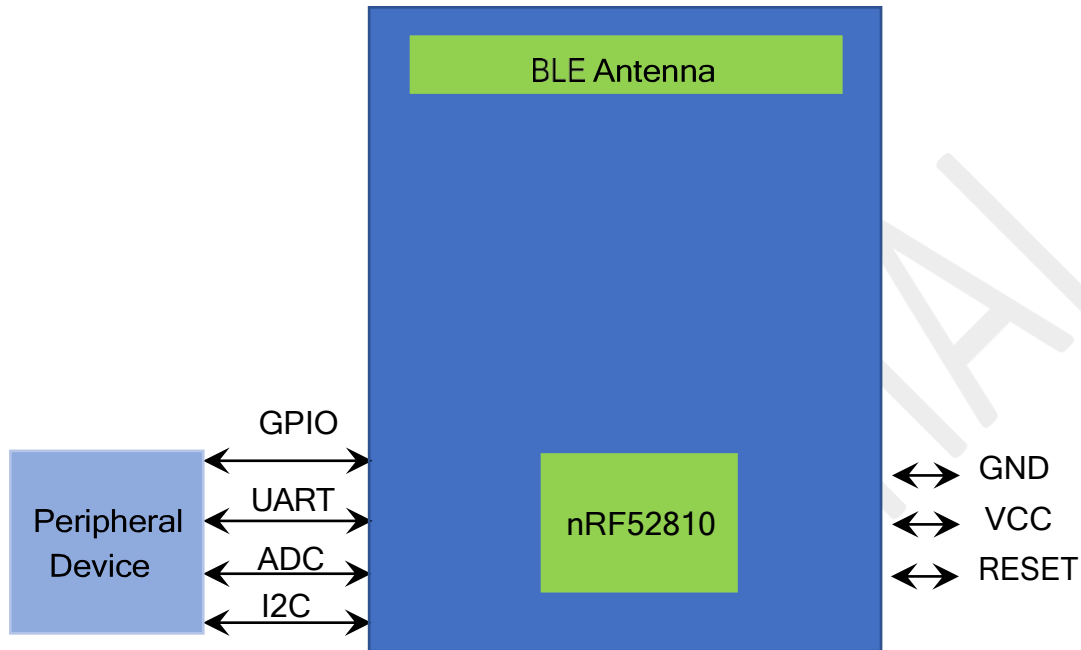



## 5. Interfaces

### Power Supply

The input voltage  $V_{cc}$  range should be 1.7V to 3.6V. Suitable decoupling must be provided by external decoupling circuitry (10  $\mu$ F and 0.1  $\mu$ F). It can reduce the noise from power supply and increase power stability.

### System Function Interfaces

#### GPIOs

The general purpose I/O is organized as one port with up to 16 I/Os enabling access and control of up to 16 pins through one port. Each GPIO can be accessed individually with the following user configurable features:

- Input/output direction
- Output drive strength
- Internal pull-up and pull-down resistors
- Wake-up from high-or low-level triggers on all pins
- Trigger interrupt on all pins
- All pin scan be used by the PPI task/event system ;the maximum number of pins that can be interfaced through the PPI at the same time is limited by the number of GPIOTE channels
- All pins can be individually configured to carry serial interface or quadrature demodulator signals
- All pins can be configured as PWM

- There are 4 ADC input in the 16 I/Os

### **Two-wire Interface (I2C Compatible)**

The two-wire interface can communicate with a bi-directional wired-AND bus with two lines (SCL, SDA). The protocol makes it possible to interconnect up to 127 individually addressable devices. The interface is capable of clock stretching, supporting data rates of 100 kbps, 250 kbps and 400 kbps.

### **Flash Program I/Os**

The module has two programmer pins, respectively SWDCLK pin and SWDIO pin. The two pin Serial Wire Debug (SWD) interface provided as a part of the Debug Access Port (DAP) offers a flexible and powerful mechanism for non-intrusive debugging of program code. Breakpoints and single stepping are part of this support.

### **Serial Peripheral Interface**

The SPI interfaces enable full duplex synchronous communication between devices. They support a three-wire (SCK, MISO, and MOSI) bi-directional bus with fast data transfers. The SPI Master can communicate with multiple slaves using individual chip select signals for each of the slave devices attached to a bus.

Control of chip select signals is left to the application through use of GPIO signals. SPI Master has double buffered I/O data. The SPI Slave includes Easy DMA for data transfer directly to and from RAM allowing Slave data transfers to occur

while the CPU is IDLE. The GPIOs are used for each SPI interface line and can be chosen from any GPIOs on the device and configured independently. This enables great flexibility in device pinout and efficient use of printed circuit board space and signal routing.

The SPI peripheral supports SPI mode 0, 1, 2, and 3. The module has 3 SPI ports and their properties are as below:

Instance	Master/Slave
SPI0	Master
SPI1	Master
SPIS1	Slave

## UARTs

The Universal Asynchronous Receiver/Transmitter offers fast, full-duplex, asynchronous serial communication with built-in flow control (CTS, RTS), support in hardware up to 1 Mbps baud. Parity checking is supported. Support the following baud rate in bps unit:

1200/2400/4800/9600/14400/19200/28800/38400/57600/76800/115200.

**Note:** The GPIOs are used for each SPI/TWI/UART interface line and can be chosen from any GPIOs on the device and configured independently.

## Analogue to Digital Converter (ADC)

The 12-bit incremental Analogue to Digital Converter (ADC) enables sampling of up to 8 external signals through a front-end multiplexer. The ADC has configurable input and reference pre-scaling, and sample resolution (8, 10, and 12 bit).

Module PIN Number	nRF52810 PINNumber	Description
3	P0.28/AIN4	General Purpose I/O
4	P0.30/AIN6	General Purpose I/O
13	P0.04/AIN2	General Purpose I/O
14	P0.05/AIN3	General Purpose I/O

## Reset

The set pin of the module is in the internal pull-high state. When the reset pin of the module is input to a low level, the module will be automatically reset. After the reset pin is used, the parameters of the current setting will not be ANT.

## 6. Module Specifications

Hardware Features	
Model	ISC-nRF52810-A
Antenna Type	PCB Antenna
Chipset Solution	nRF52810
Voltage	1.7V~3.6V
Dimensions (L x W x H)	18x12x2mm
Wireless Features	
Wireless Standards	BLE5.3,ANT
Frequency Range	2400MHz-2483.5MHz
Data Rates	1-2Mbps
Wireless Security	AES HW Encryption
Transmit Power	TxPower-20to+4dBmin4dBSteps
Operating Mode	Central/ Peripheral in BLE

## 7. Module Pin-out and Pin Description

### Schematic Symbol

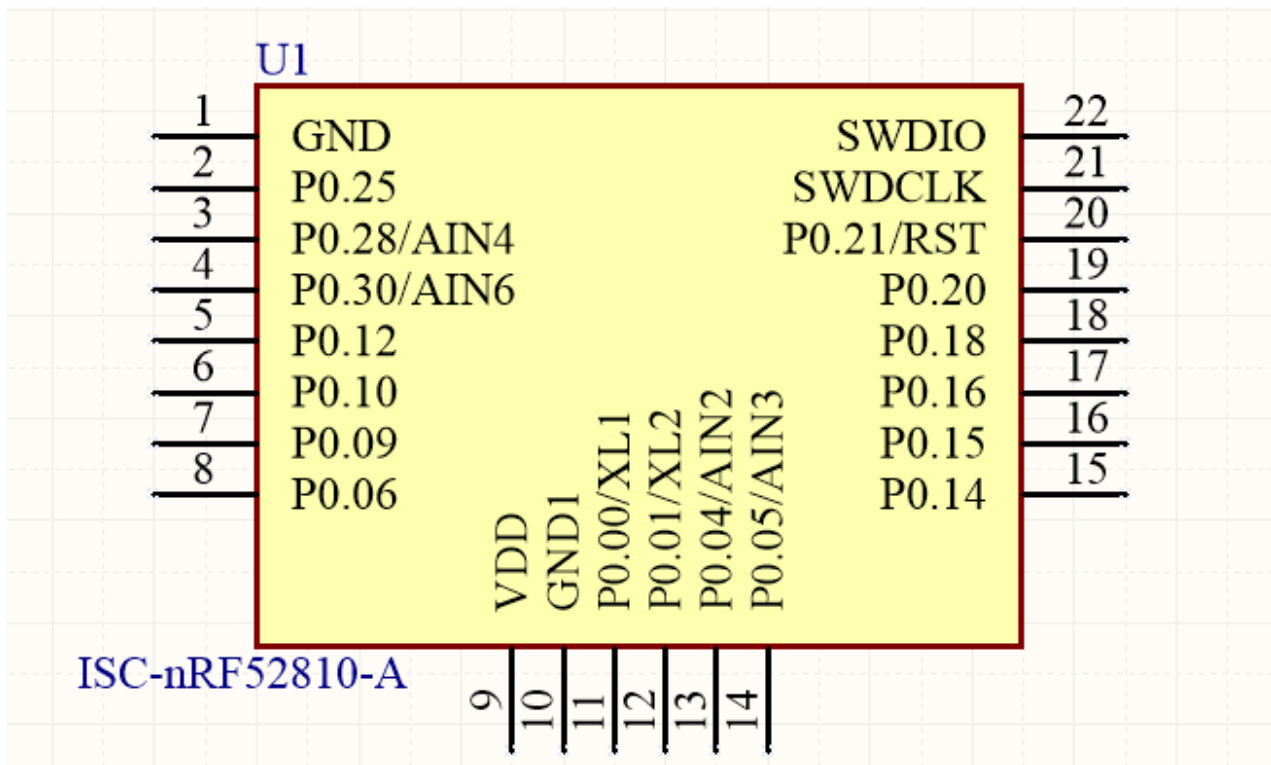

### PCB Footprint

Please contact ISC technical team for Altium SCH and PCB library or email to [sales@indiesemic.com](mailto:sales@indiesemic.com) or [nikul.shah@indiesemic.com](mailto:nikul.shah@indiesemic.com)

## Pin Description

Pin No.	Pin Name	nRF52810 MCUPin	Pin Description
1	GND	GND	GND
2	P25	P25	General purpose I/O pin.
3	P28/ AIN4	P28	General purpose I/O pin.
		AIN4	Analogue input
4	P30/ AIN6	P30	General purpose I/O pin
		AIN6	Analogue input
5	P12	P12	General purpose I/O pin
6	P10	P10	General purpose I/O pin
7	P09	P09	General purpose I/O pin
8	P06	P06	General purpose I/O pin
9	P10	VDD	PWR
10	GND1	GND1	GND
11	P0.00/ XL1	P00	General purpose I/O pin
		XL1	Reserved
12	P0.01/ XL2	P01	General purpose I/O pin
		XL2	Reserved
13	P04/ AIN2	P04	General purpose I/O pin
		AIN2	Analogue input
14	P05/ AIN3	P05	General purpose I/O pin
		AIN3	Analogue input
15	P14	P14	General purpose I/O pin
16	P15	P15	General purpose I/O pin
17	P16	P16	General purpose I/O pin

18	P18	P18	General purpose I/O pin
19	P20	P20	General purpose I/O pin
20	P21/ RST	P21	General purpose I/O pin
		RST	Configurable as pin Reset
21	SWDCLK	SWDCLK	Programming clock
22	SWDIO	SWDIO	Programming Data



## 8. Electrical Characteristics

### Absolute Maximum Ratings

Parameter	Condition	Min.	Typical	Max.	Unit
Storage Temp.		-40		125	°C
ESD Protection				4000	V
Supply Voltage		-0.3		3.9	V
Voltage on I/O Pin		-0.3		3.6	V

### 8.2. Recommended Operating Ratings

Parameter	Symbol	Min.	Typical	Max.	Unit
Operating Temp.	TA	-40		85	°C
Power Supply	VCC	1.7	3.3	3.6	V
Input Low Voltage	VIL	-0.3		0.3*VCC	V
Input High Voltage	VIH	0.7*VCC		VCC	V

### 8.3. Current Ratings

System State	TX Peak @4dBm	RX Peak	Sleep Mode (Average)	Idle Mode (Average)
Current (peak)@3V	7.5mA	10mA	2.5uA	2.5uA

CONFIDENTIAL

## 9. Ordering Information

Module No	Shielding	Antenna
ISC-nRF52840-A	No	PCB

CONFIDENTIAL