



Shenzhen Hi-Link Electronic Co., Ltd

1W DC/DC power module Type A

HLK-1D0505A/ HLK-1D0512A/ HLK-1D0515A/ HLK-1D0524A



Contents

1. DC/DC power module.....	1
2. Product model.....	1
3. Product Features.....	1
4. Environment conditions.....	2
5. Electrical characteristics.....	2
5.1. Input Features.....	2
5.2. Output characteristics (5V/200mA).....	3
5.3. Output characteristics (12V/84mA).....	4
5.4. Output characteristics (15V/67mA).....	5
5.5. Output characteristics (24V/42mA).....	6
6. Product characteristic curve	7
7. Typical applied circuit.....	7
7.1 EMC parameter recommendation.....	7
7.2 Normal application.....	8
8. Test application.....	9
8.1. DC/DC Test circuit.....	9
8.2. Ripple and noise test.....	9
8.3. Product application considerations.....	10
9. Marking, packaging, transportation, storage.....	10
9.1. Marking.....	10
9.1.1. Product mark.....	10
9.1.2. Packaging mark.....	10
9.2. Packaging.....	11
9.3. Transportation.....	11
9.4. Storage.....	11
10. Dimension and weight.....	11

1. DC/DC Power module

1W series DC-DC power module is one type power supply module with small size, high efficiency, tiny power, constant voltage, input isolation and unregulated, single output; this series of products is specially designed to generate a group of isolated voltage to input power supply in the on-board power system applications. This product is suitable for purely digital circuits, general low-frequency analog circuits, relay drive circuits, data exchange circuits, etc.

2. Product Model

Model	Shell size (mm)	Output power (W)	Output voltage (V)	Output current (mA)	Notes
HLK-1D0505A	11.5*10*6	1	5	200	
HLK-1D0512A		1	12	84	
HLK-1D0515A		1	15	67	
HLK-1D0524A		1	24	42	

3. Product Features

1. Small SIP package
2. Conversion efficiency 88% (Typ)
3. Isolation between input and output is required (isolation voltage $\leq 1500\text{VDC}$)
4. No-load input current as low as 5mA
5. The voltage of the input power supply is relatively stable (voltage variation range $\pm 10\% V_{in}$)
6. Operating temperature range: $-40^{\circ}\text{C} \sim +85^{\circ}\text{C}$
7. Output short-circuit protection, low requirements for output voltage stability
8. Low ripple / noise (20MH bandwidth): 30mVp-p (typ)
9. International standard pins, PCB board in-line installation
10. Adopting high-quality environmental protection waterproof and thermally conductive adhesive potting, moisture-proof, vibration-proof, meet the waterproof and dustproof IP65 standard
11. High reliability, long life design, long continuous working time

4. Environment conditions

Items	Technical parameters	Unit	Remarks
Working temperature	-40—+85	℃	
Storage temperature	-40—+80	℃	
Relative humidity	5—95	%	
Heat dissipation method	Natural cooling		
Atmospheric pressure	80—106	Kpa	
Vibration	Vibration coefficient: 10~500Hz,2G10min./1cycle, 60min.each along X,Y,Z axes		Meet secondary road transport requirements

5. Electrical characteristics

5.1. Input Features

Items	Working conditions	Unit	Remarks
Rated input voltage	5	Vdc	
Input voltage range	4.5-5.5	Vdc	
Max input current	≤0.3	A	
Reflected ripple current	15	mA	DC 5V rated input voltage series
Impulse voltage	≤9	Vdc	
Starting voltage	4.5	Vdc	
Input under voltage protection	---	Vdc	
Start delay time	---	ms	Rated input voltage and constant resistance load
Input filter type			Capacitive filtering
Hot plug			No-support
Remote end (Ctrl)*	Module open		--
	Module closed		--
	Input current when turned off	mA	-- -- --

Notes: Test at room temperature

5.2. Output Characteristics (5V/200mA)

Items	Technical parameters	Unit	Remarks
No-load rated output voltage	5V±15%	Vdc	
Short time maximum output current	≥220	mA	
Rated output current	200	mA	
Voltage regulation	±1.2	%	
Load Regulation	±15	%	
Conversion efficiency	Vin=5Vdc, Output full load 88	%	
Output ripple and noise (mVp-p)	≤80 Pure resistive load, 20MHz bandwidth, peak to peak value	mV	
Output voltage regulation	---	-	No adjustment
Output over-current protection	----	A	
Output short circuit protection	----		
Output over-voltage protection	Output 110-160% of the maximum voltage	Vdc	
Insulation voltage	Input-output, test time 1 minute, leakage current less than 1mA/1500V	-	
Insulation resistance	Input-output, insulation voltage 500VDC/1000MΩ	MΩ	
Isolated capacitor	Input-output, 100KHz/0.1V 20pF	-	

Notes: ①Ripple and noise test method, Twisted pair test method.

5.3. Output Characteristics(12V/84mA)

Items	Technical parameters	Unit	Remarks
No-load rated output voltage	12V±15%	Vdc	
Short time maximum output current	≥94	mA	
Rated output current	84	mA	
Voltage regulation	±1.2	%	
Load Regulation	±15	%	
Conversion efficiency	Vin=5Vdc, Output full load 88	%	
Output ripple and noise (mVp-p)	≤80 Pure resistive load, 20MHz bandwidth, peak to peak value	mV	
Output voltage regulation	---	-	No adjustment
Output over-current protection	----	A	
Output short circuit protection	1	S	
Output over-voltage protection	Output 110-160% of the maximum voltage	Vdc	
Insulation voltage	Input-output, test time 1 minute, leakage current less than 1mA/1500V	-	
Insulation resistance	Input-output, insulation voltage 500VDC/1000MΩ	MΩ	
Isolated capacitor	Input-output, 100KHz/0.1V 20pF	-	

Notes: ①Ripple and noise test method, Twisted pair test method.

5.4. Output Characteristics (15V/67mA)

Items	Technical parameters	Unit	Remarks
No-load rated output voltage	15V±15%	Vdc	
Short time maximum output current	≥77	mA	
Rated output current	67	mA	
Voltage regulation	±1.2	%	
Load Regulation	±15	%	
Conversion efficiency	Vin=5Vdc, Output full load 88	%	
Output ripple and noise (mVp-p)	≤80 Pure resistive load, 20MHz bandwidth, peak to peak value	mV	
Output voltage regulation	---	-	No adjustment
Output over-current protection	----	A	
Output short circuit protection	1	S	
Output over-voltage protection	Output 110-160% of the maximum voltage	Vdc	
Insulation voltage	Input-output, test time 1 minute, leakage current less than 1mA/1500V	-	
Insulation resistance	Input-output, insulation voltage 500VDC/1000MΩ	MΩ	
Isolated capacitor	Input-output, 100KHz/0.1V 20pF	-	

Notes: ①Ripple and noise test method, Twisted pair test method.

5.5. Output Characteristics (24V/42mA)

Items	Technical parameters	Unit	Remarks
No-load rated output voltage	24V±15%	Vdc	
Short time maximum output current	≥52	mA	
Rated output current	42	mA	
Voltage regulation	±1.2	%	
Load Regulation	±15	%	
Conversion efficiency	Vin=5Vdc, Output full load 88	%	
Output ripple and noise (mVp-p)	≤100 Pure resistive load, 20MHz bandwidth, peak to peak value	mV	
Output voltage regulation	---	-	No adjustment
Output over-current protection	----	A	
Output short circuit protection	1	S	
Output over-voltage protection	Output 110-160% of the maximum voltage	Vdc	
Insulation voltage	Input-output, test time 1 minute, leakage current less than 1mA/1500V	-	
Insulation resistance	Input-output, insulation voltage 500VDC/1000MΩ	MΩ	
Isolated capacitor	Input-output, 100KHz/0.1V 20pF	-	

Notes: ①Ripple and noise test method, Twisted pair test method.

6. Product characteristic curve

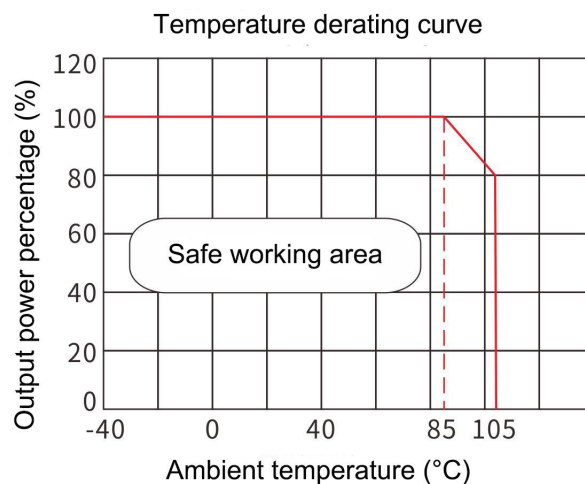
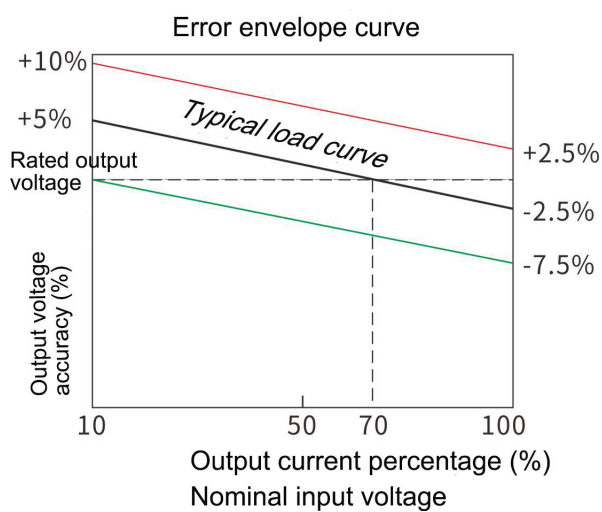

7. Typical applied circuit

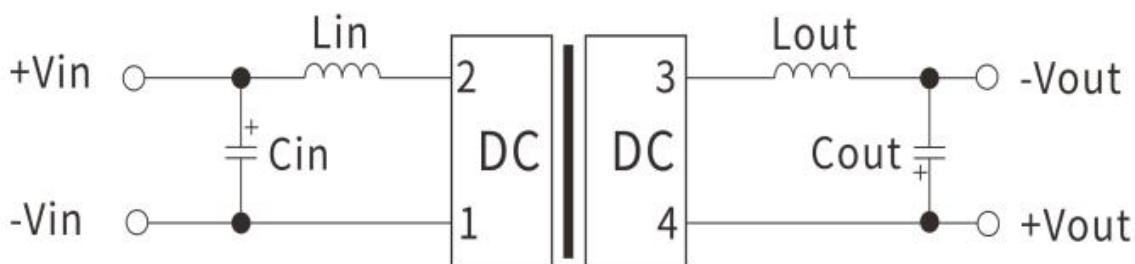

Figure 2

7.1 EMC Parameter recommendation

Component Tag / Recommended accessory	Function	Recommended value
C_{in} capacitance	Filter capacitor	4.7uF/50V
C_{out} capacitance	Filter capacitor	2.2-10uF/50V
L_{in} inductance	Filter inductor	Inductance: 4.7uH
L_{out} inductance	Filter inductor	Inductance: 4.7uH

Note: Output load requirements

In order to ensure that the module can work efficiently and reliably, its minimum output load must not be less than 10% of the rated load during use. If your required power is really small, please connect a resistor in parallel between the positive and negative poles of the output (the sum of the actual power used by the resistor is greater than or equal to 10% of the rated power and the rated power of the selected resistor must be more than 5 times the actual power , otherwise the temperature of the resistor will be higher)

7.2 Normal application

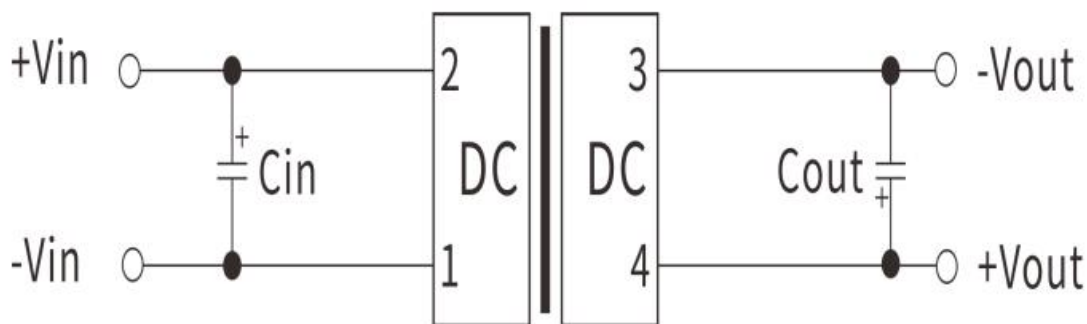

Figure 1

1. If it is required to further reduce the input and output ripple, a capacitor filtering network can be connected to the input and output ends, the applied circuit as showed on figure 1. However, it should be careful to select a suitable filter capacitor. If the capacitance is too large, it may cause start-up problems. For each output, under the conditions of ensuring safe and reliable operation

Component Tag / Recommended accessory	Function	Recommended value
Cin capacitance	Filter capacitor	4.7uF/50V
Cin capacitance	Filter capacitor	10uF/50V

2. In order to ensure that the module can work efficiently and reliably, its minimum output load must not be less than 10% of the rated load during use. If your required power is really small, please connect a resistor in parallel between the positive and negative poles of the output (the sum of the actual power used by the resistor is greater than or equal to 10% of the rated power and the rated power of the selected resistor must be more than 5 times the actual power , otherwise the temperature of the resistor will be higher)

8. Test application

8.1. DC/DC Test circuit

Generally recommended capacitor: 0.1uF polypropylene capacitor and 4.7uF high-frequency low-resistance electrolysis in parallel

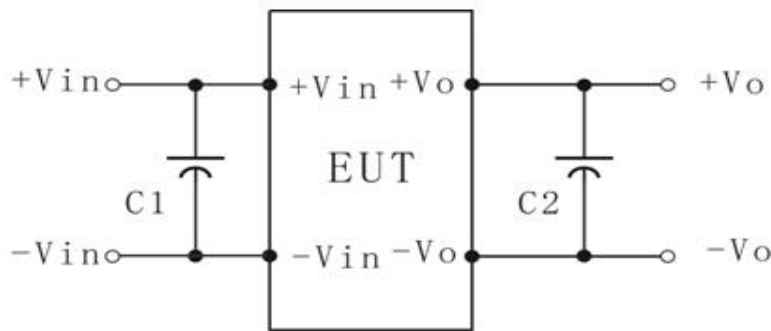

8.2. Ripple and noise test

(Twisted pair method, 20MHZ bandwidth)

Testing method:

(1) Ripple noise is connected by 12# twisted pair. The oscilloscope bandwidth is set to 20MHz, 100M bandwidth probe, and 0.1uF polypropylene capacitor and 47uF high frequency low resistance electrolytic capacitor are connected in parallel on the probe end. The oscilloscope sampling uses Sample sampling mode.

(2) Schematic diagram of output ripple&noise test:

Connect the power input terminal to the input power supply terminal. The power output is connected to the electronic load through the fixture board. The test uses a 30cm ± 2 cm sampling line to sample directly from the power output port.

The power line selects the insulated wire with the corresponding wire diameter according to the magnitude of the output current.

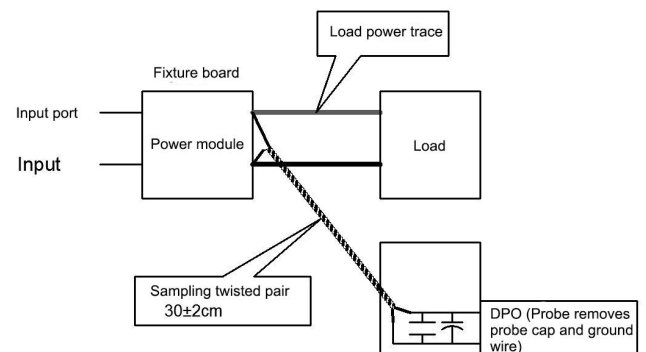

8.3. Product application considerations

1. Input requirements: Ensure that the output voltage fluctuation range of the power supply does not exceed the input requirements of the DC / DC module itself, and the output power of the input power supply must be greater than the output power of the DC / DC module.
2. One recommended circuit: For applications where ripple and noise requirements are normal, a filter capacitor can be connected in parallel at the input and output ends. The external circuit is shown in the following figure1 with the recommended value details of the filter capacitor. Output load requirements: Try to avoid no-load use. When the actual power consumption of the load is less than 10% of the rated output power of the module or there is no-load phenomenon, it is recommended that a dummy load be connected to the output end. The dummy load (resistance) can be calculated by 5~10% of the rated power of the module, resistance value = $U_{out} / (1W * 10\%)$.
3. Over-load protection: Under normal operating conditions, the output circuit of this product has no protection function against overload conditions. The easiest way is to connect a resettable fuse in series at the input end, or add a circuit breaker to the circuit.
4. The external capacitor of the output terminal should not be too large, otherwise it will easily cause over-current or poor start-up when the module starts.
5. If the product works below the minimum required load, the performance of the product cannot be guaranteed to meet all performance indications in this manual.
6. The maximum capacitive load is tested under the input voltage range and full load condition.
7. Unless special instructions, all indexes in this manual are measured at the condition, $T_a = 25\text{ }^\circ\text{C}$, humidity <75% RH, nominal input voltage and output rated load.

9. Marking, packaging, transportation, storage

9.1. Marking

9.1.1. Product mark

The product's unique bar code mark is attached to the appropriate position of the product to ensure traceability of the manufacturing date, product batch, etc. of each product. Its content meets the requirements of national standards and industry standards.

9.1.2. Packaging mark

The product packaging box is marked with the name of the manufacturer, the factory

address, the zip code, the product model, the manufacturing date (year, month and day); It is marked with "upward", "moisture-proof" and "Be careful" transport signs, all of which comply with the provisions of GB 191. .

9.2. Packaging

The product is packaged in a special blister box, which has anti-vibration function and complies with GB 3873.

9.3. Transportation

The packaged product can be transported by any means of transport. There should be awnings during transportation, and there should be no severe vibration or impact.

9.4. Storage

Product storage should comply with the provisions of GB 3873.

10. Dimension and weight

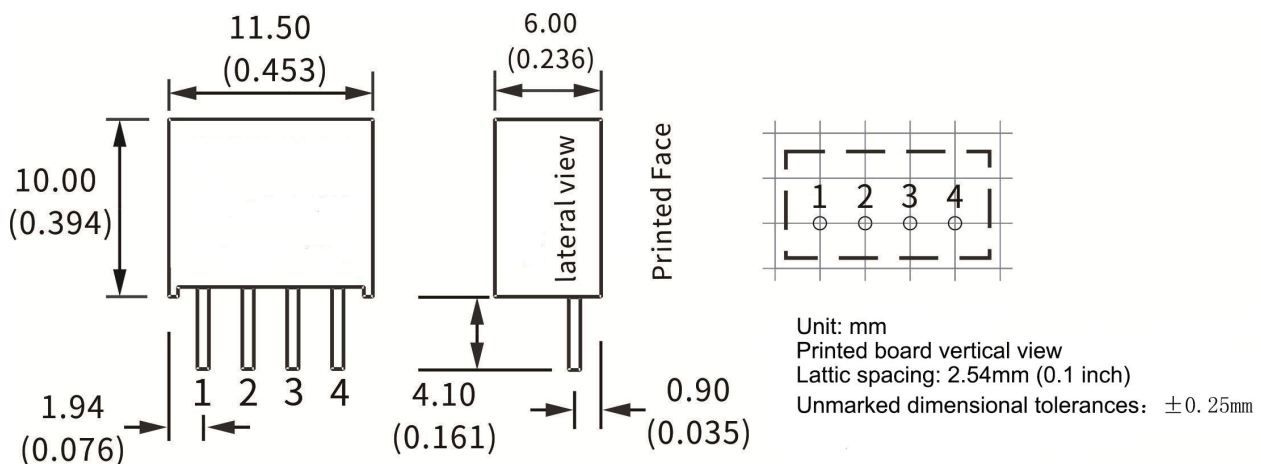

1	2	3	4	5	6
VIN-	VIN+	VO-	VO+	--	---
Input negative	Input positive	Output negative	Output positive	--	---

The product weight is about 1.6g